

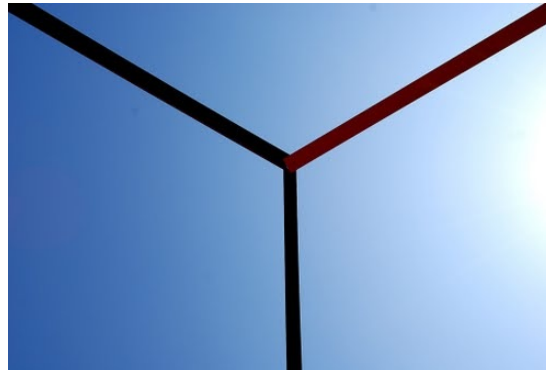

# Probing Broken Symmetries: The Higgs Boson and Beyond

Kalanand Mishra, *Fermilab*



University of Pittsburgh  
January 30, 2014

# Outline

- ▶ **Higgs boson discovery**
- ▶ **Its measurements at the LHC**
- ▶ **Probes of new physics in broken symmetry**
- ▶ **Summary**

# Higgs boson discovery



## Physicists Find Elusive Particle Seen as Key to Universe

### The New York Times



Chasing the Higgs Boson | INTRODUCTION | PROMISED FIREBALLS | GAME OF BUMPS | STILL MISSING | OOZING INTO VIEW | OPENING THE BOX

## Chasing the Higgs Boson

The first time that the entire NYT Science section is devoted to a single story

the Large Hadron Collider near Geneva, two of scientists struggled to close in on physics' elusive particle.

By DENNIS OVERBYE

EL PAÍS

INTERNACIONAL | POLÍTICA | ECONOMÍA | CULTURA | SOC

Switzerland – Vivek missed his daughter.

## Hallada “la más sólida evidencia” de la existencia del bosón de Higgs

El posible descubrimiento de la partícula es un paso esencial hacia la explicación del origen de la materia

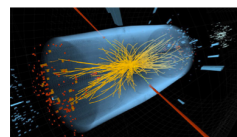

“Puedo confirmar que se ha descubierto una partícula que es consistente con la teoría del bosón de Higgs”, dicen los científicos. El descubrimiento de la partícula ayudará a explicar el origen de la masa. Los físicos del CERN explican en estos momentos sus hallazgos

- Diccionario para entender en qué consiste el hallazgo
- La “caja” del bosón de Higgs, por A. RUZ ZAPENCO
- VIDEO: Una explicación del bosón de Higgs
- Sigue en directo la conferencia del CERN
- FOTOGALERÍA: Indicios hallados de la ‘partícula de Dios’
- ‘Nació la partícula de Dios’, por JAYESH SHARMA



Illustration by Sean McCabe/Photographs by Daniel Auf der Maur, Toni Albit, Fabrice Coffini, Fred J. Peter Higgs, center, of the University of Edinburgh, was one of the first to propose the particle's existence. From left, physicists at CERN who helped lead the hunt for it: Sau Lan Wu, Joe Incandella, Guido Tonelli and Fabiola Gianotti.



# It was a big event in Pittsburgh also

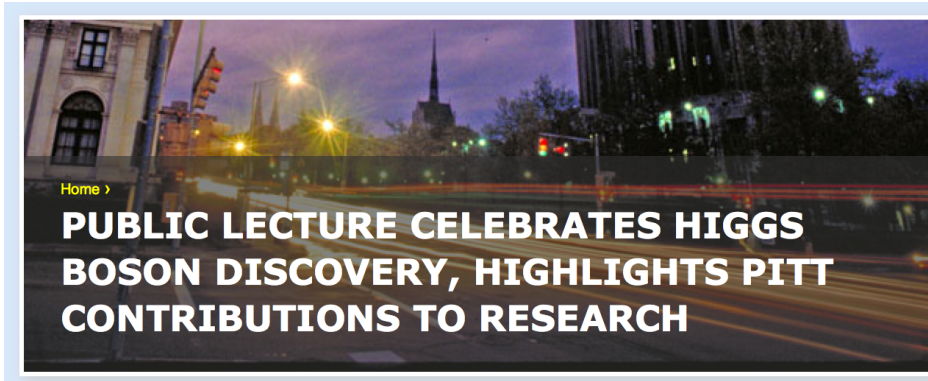

Phenomenology

ATLAS experiment



In addition, Pittsburgh natives in key leadership positions in both ATLAS and CMS experiments

# Happy Birthday, Mr. Higgs !



2013 has been a great year for the Higgses (both Peter and the Boson) !

Established the existence of new particle beyond any doubts



2013 Nobel Prize to François Englert & Peter Higgs, “*for the theoretical discovery of a mechanism that contributes to our understanding of the origin of mass of subatomic particles, and which recently was confirmed through the discovery of the predicted fundamental particle, by the ATLAS and CMS experiments at CERN’s Large Hadron Collider*”.

But what it has to do with broken symmetry ?

Let’s try to understand using a familiar example

# An example of broken symmetry

Full symmetry, all jerseys are equal

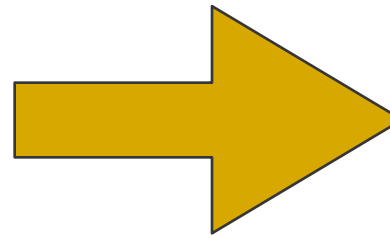

picked one  
and assigned  
to a player



What happened?

1. Identity created
2. Symmetry broken

**Question:** Who broke the symmetry ?

- a.) Ben Roethlisberger    b.) One of the jerseys    c.) I did it

# How does the Nature do it ?

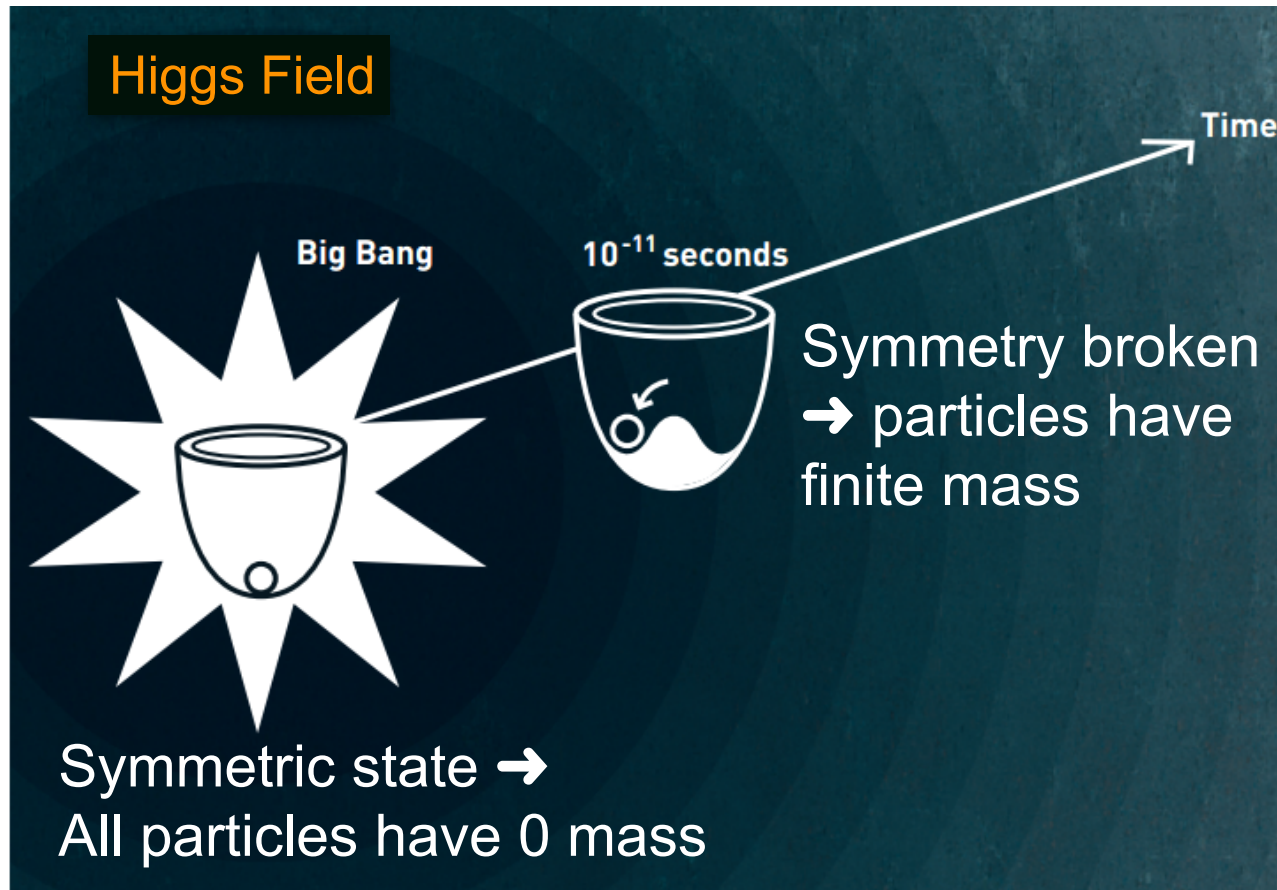

**Question:** Who broke the symmetry ?

# Consequence of symmetry breaking

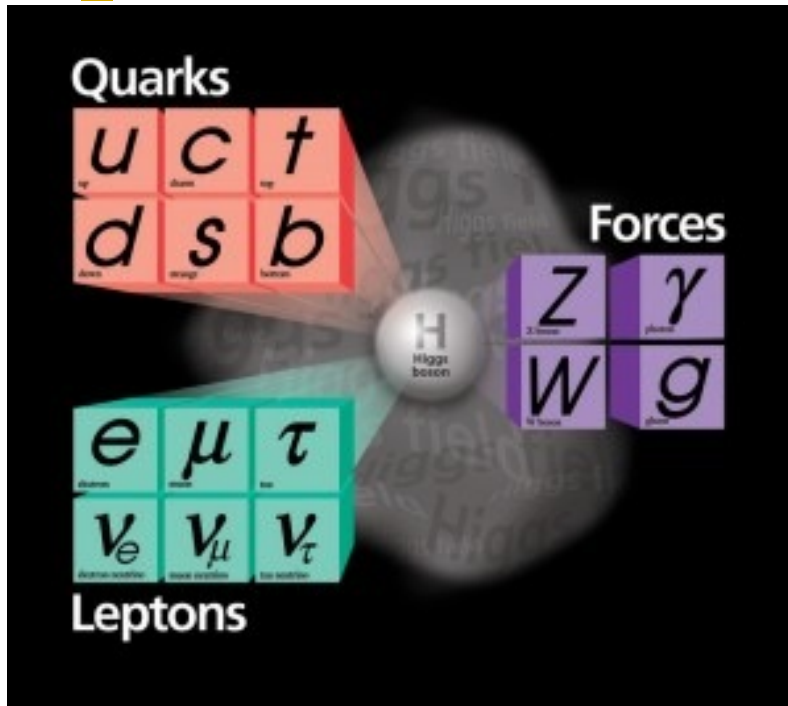

all masses due to Higgs  
( $\nu$  masses not so clear)

**Moral of the story: why believe in the idea of Higgs field ?**

→ because it correctly predicted the existence of a Higgs boson

Higgs field gives mass to

- Force carriers: W and Z bosons
- Matter particles: quarks & leptons
- **And to Higgs boson itself !**

# A quick question ...

Who gives mass to the atom: is it also the Higgs field?

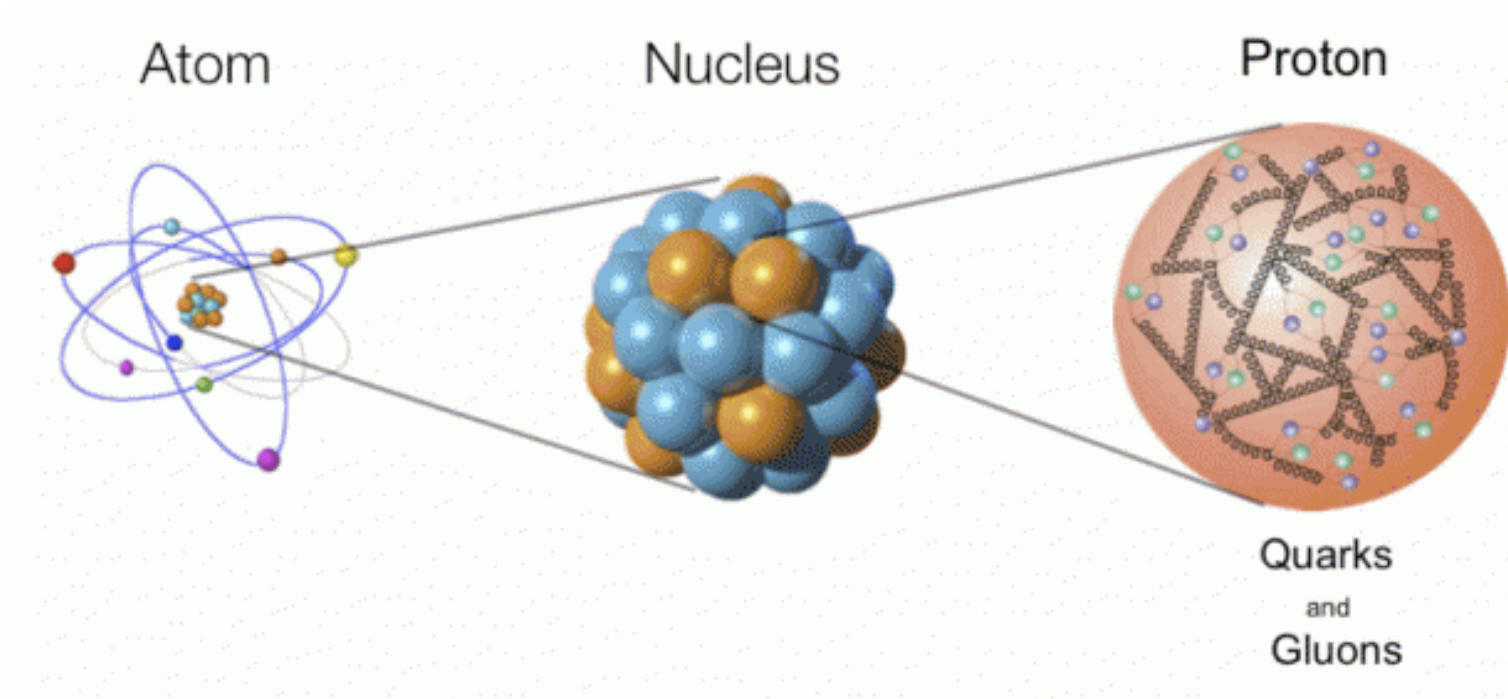

**Hints:** proton mass  $\approx 1$  billion electron volt  
light quark mass  $\approx 0$  billion electron volt  
gluon mass = 0 billion electron volt

## Extra credit

So, the Higgs field doesn't give mass to the atom !

→ Extra credit if you figured out that  $> 99.99\%$  of the mass of the universe is **NOT** due to the Higgs field.

Just like not all touchdowns are scored by the offense ...



Troy Polamalu scores a touchdown on an interception against Cincinnati Bengals

Then why I am giving this talk ?

# In a world without Higgs boson

1. Quarks and leptons would remain massless
    - Nucleon mass little changed, but **proton outweighs neutron**
  2. W, Z boson masses → (1/2500 × observed)
    - Rapid  $\beta$ -decay ⇒ lightest nucleus is one neutron
      - ⇒ no hydrogen atom
      - ⇒ no chemistry
      - ⇒ no stable structures like solids and liquids
- ... character of the physical world would be profoundly changed

**Moral of the story: Higgs boson is crucial to our existence**

# Outline

- ▶ Higgs boson discovery
- ☑ **Its measurements at the LHC**
- ▶ Probes of new physics in broken symmetry
- ▶ Summary

# The Large Hadron Collider

Creates particles in conditions similar to Big Bang

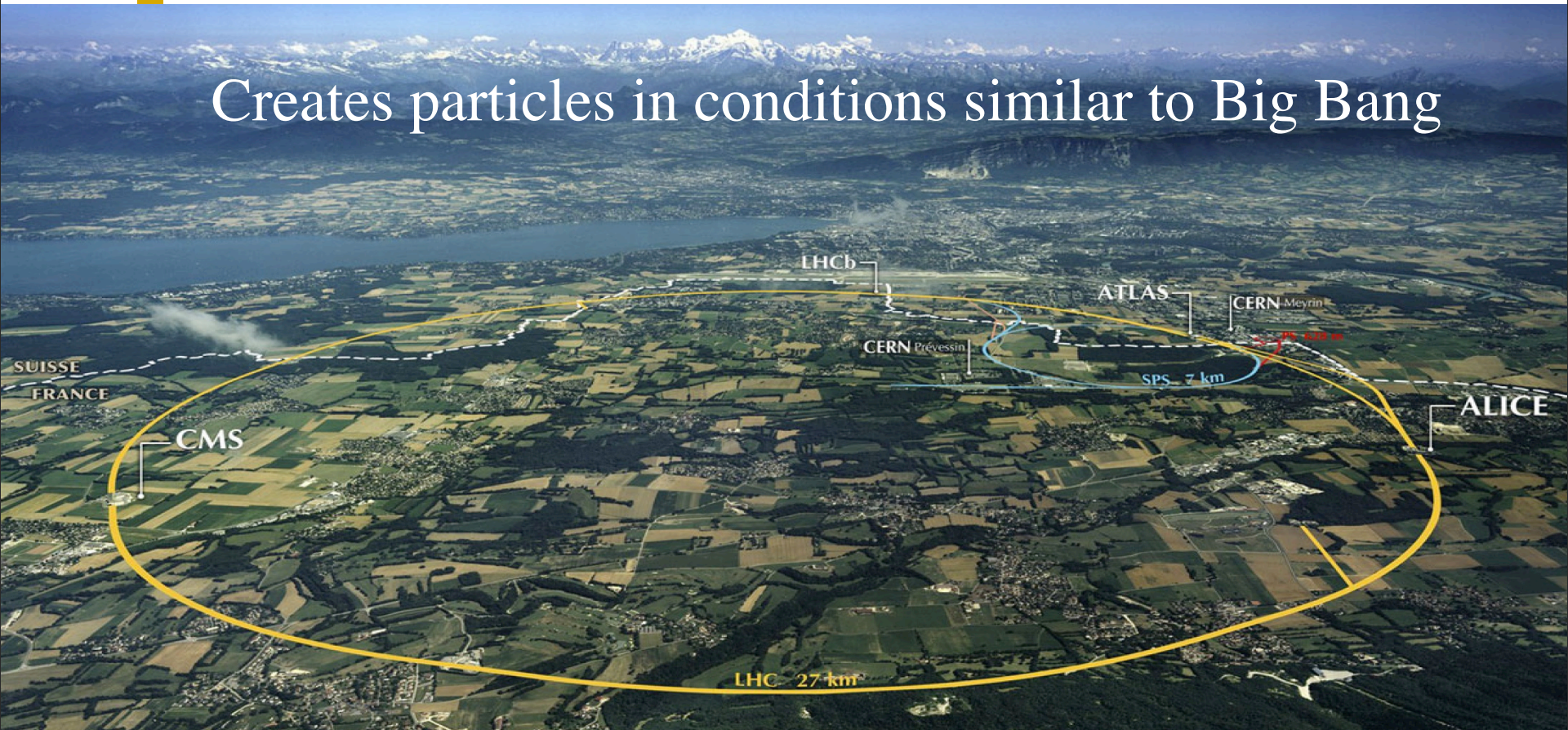

- Proton–proton beams, the world’s highest energy collider
  - Run 1: 2009-13, energy: 7-8 TeV (data mostly analyzed)
  - Run 2: 2015-18, energy: 13-14 TeV (under preparation)

# Two multi-purpose detectors: ATLAS and CMS

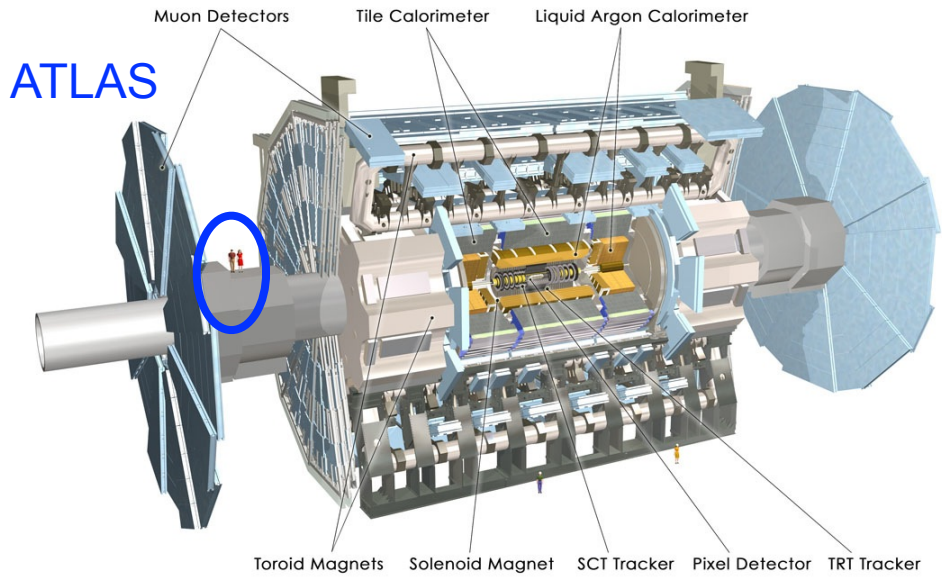

- Both have similar components
- Large diverse physics program
- I've been a member of the CMS collaboration

	ATLAS	CMS
length	46 m	22 m
height	25 m	15 m
weight	7000 T	12500 T
B field	2 Tesla	4 Tesla
scientists	~3000	~3000
papers	~300	~300

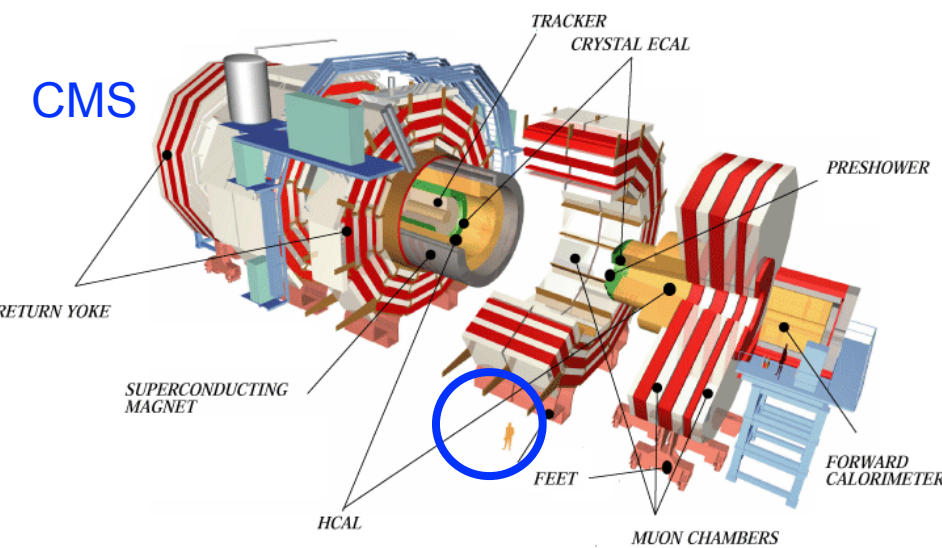

# Detection of final state particles

## Cut away of the CMS detector

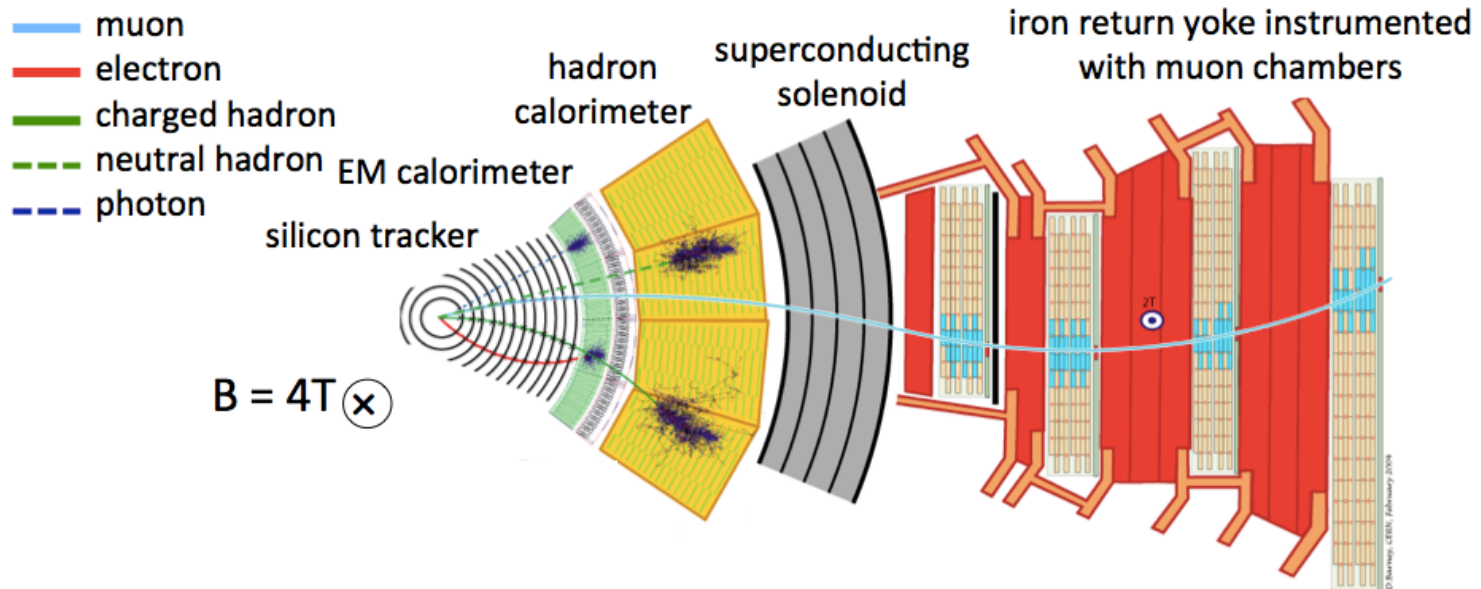

The results I will show today rely most critically on

- electrons: track matched to clusters in EM calorimeter
- muons: tracks, penetrate deep in muon system
- jets: constructed with combined tracking + calo info
- MET: combined tracking + calo info, hermetic detector
- photons: clusters in EM calorimeter

# A clean Higgs boson event in data

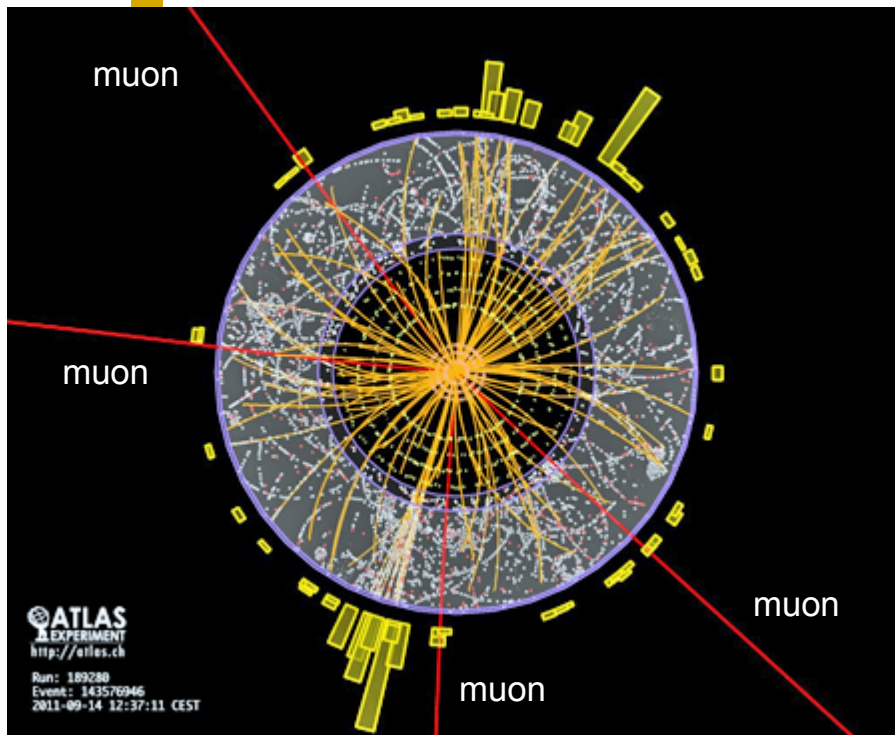

## Signal

Higgs boson decays to two Z bosons  
 $H \rightarrow ZZ$

Both Z bosons decay to two muons  
 $Z \rightarrow \mu^+ \mu^-$

## Background

Any other process with 4 muons

Question: what kind of background can give 4 muons?

Hints: 1.) Z boson production rate is high

2.) Muon can radiate a photon and then  $\gamma \rightarrow \mu^+ \mu^-$

# Understanding the mass peak

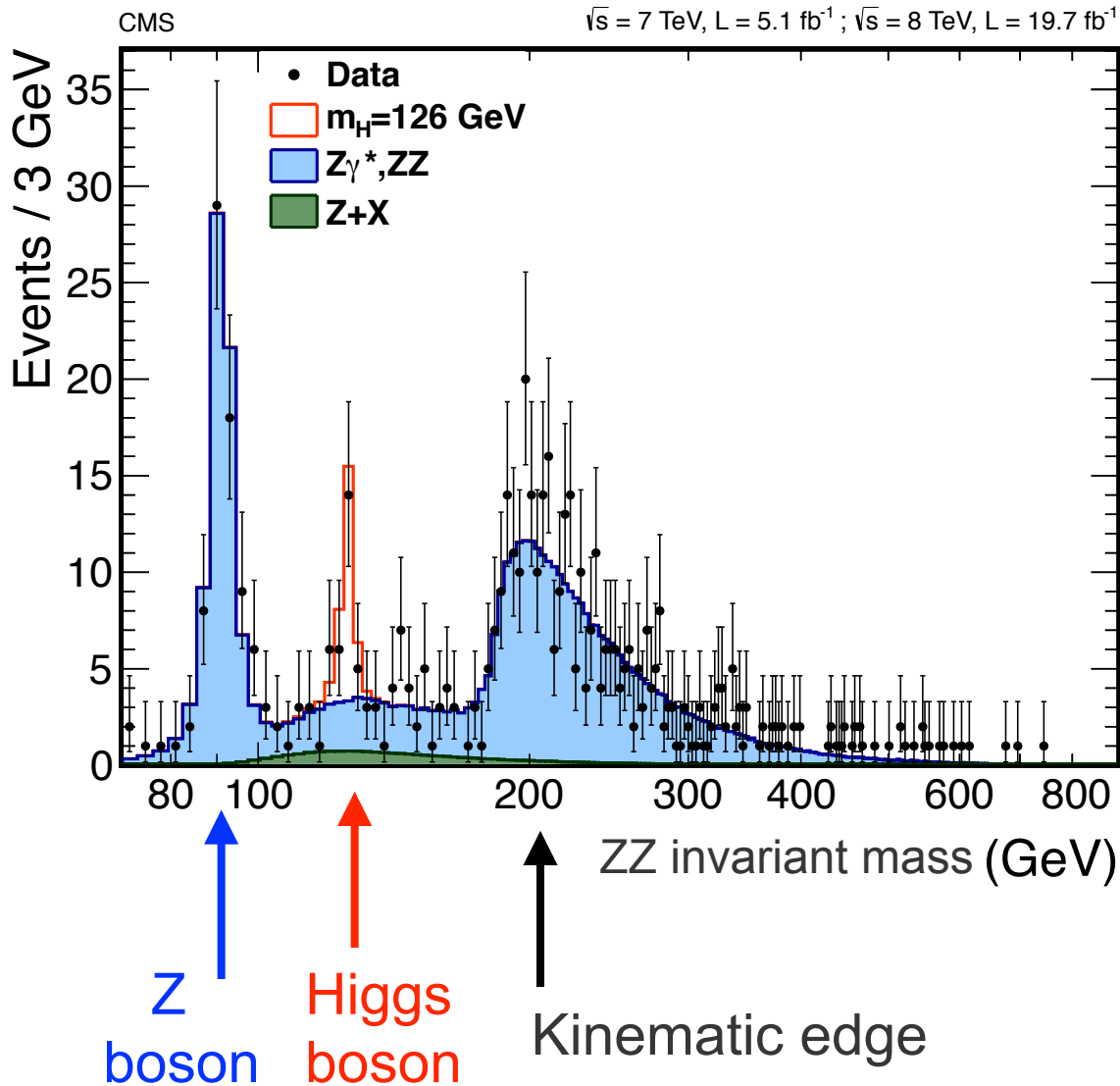

Question: how many peaks you see here ?

Hint: 0, 1, 2, or 3 ?

# Higgs boson mass

Mass peak,  $M_H = 125.7 \pm 0.4$  GeV  
precision: **0.3%**

More precise than all quark masses !!!  
Less precise than the W and Z masses.

From the Particle Data Group

top quark	$173.07 \pm 0.88$	GeV
b quark	$4.18 \pm 0.03$	GeV
c quark	$1.275 \pm 0.025$	GeV
W boson	$80.385 \pm 0.015$	GeV
Z boson	$91.1876 \pm 0.0021$	GeV

Question: What is the Higgs boson width ?

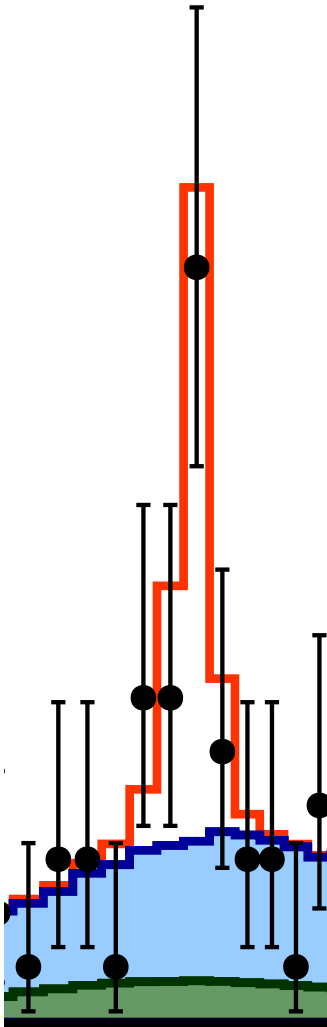

# An interesting thing about $M_H = 126$ GeV

Higgs mass of 126 GeV  $\Rightarrow$  metastable vacuum !!!

Dangerously close to both stable and unstable vacua

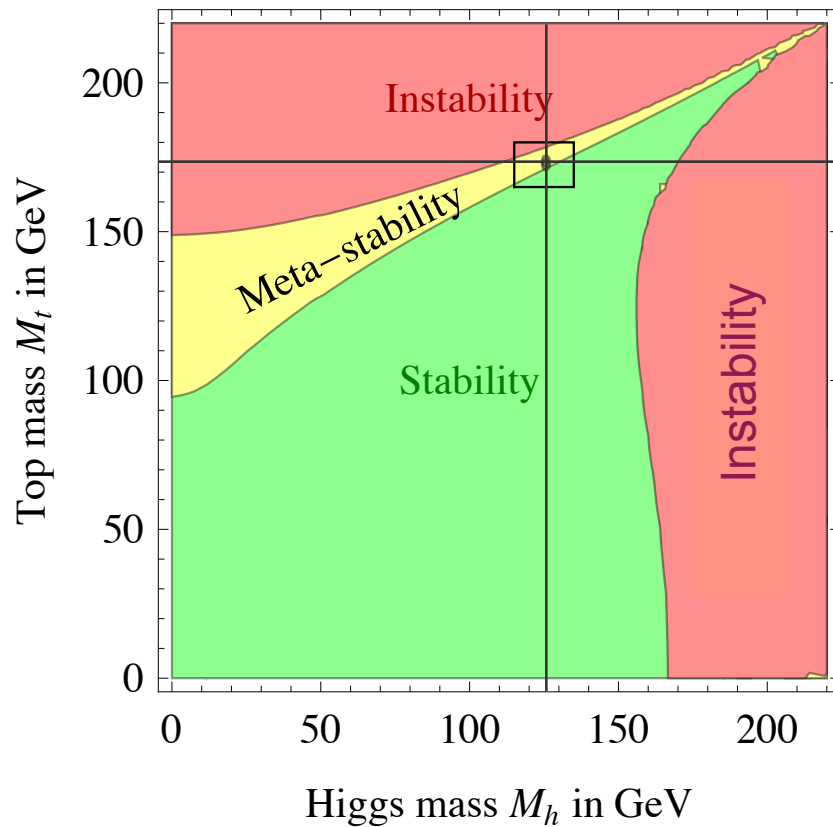

Degrassi et al, arXiv: 1205.6497

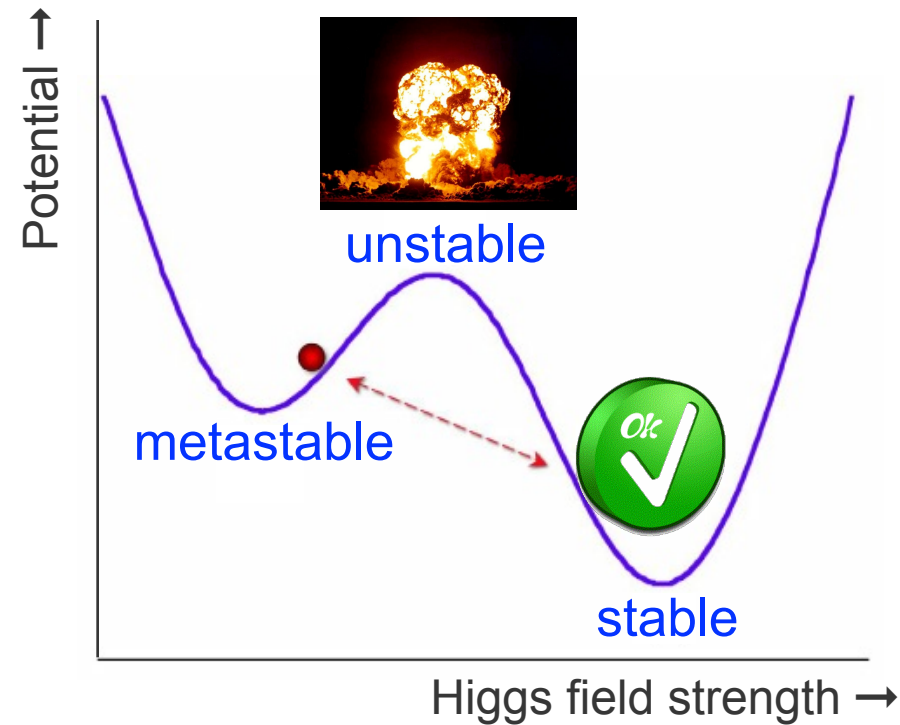

Higgs mass fine-tuned in a narrow range  $\Rightarrow$  significance ?

# An interesting thing about $M_H = 126$ GeV

Observed mass = Bare mass + quantum correction

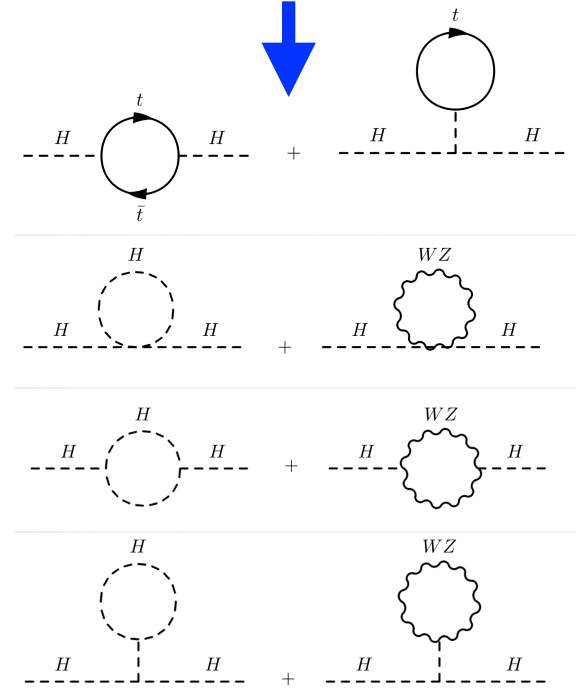
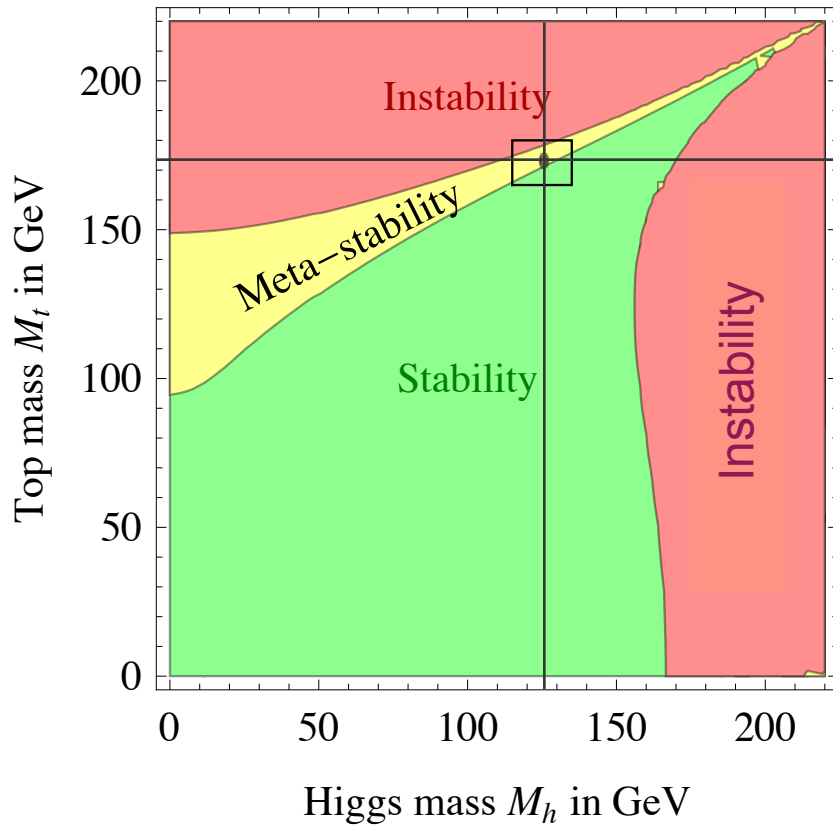

$$m_H^2 = (m_H^0)^2 + \frac{3}{8\pi^2 v^2} [m_H^2 + 2m_W^2 + m_Z^2 - 4m_t^2] \Lambda^2 .$$

Large terms with different signs cancel only if  $M_H$  is fine-tuned in a narrow range

# How weird is it ? Here is an analogy

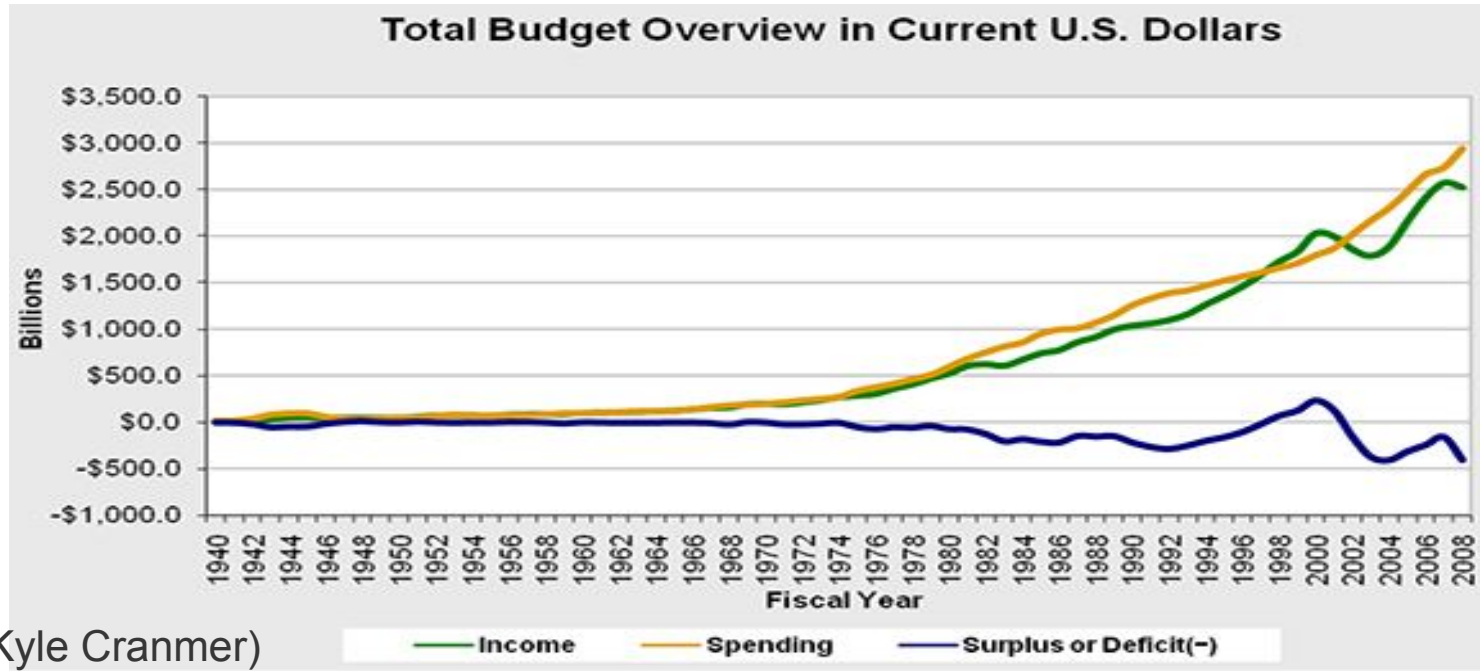

(courtesy Kyle Cranmer)

Income ↔ Positive contributions to the Higgs mass

Spending ↔ Negative contributions to the Higgs mass

Surplus ↔ Physical Higgs mass

Fiscal Year ↔ Cutoff Energy Scale

Adjusted for inflation ↔ Renormalization

However, there is a brighter side to it



Can measure Higgs decay in many final states

Not the easiest,  
but very important

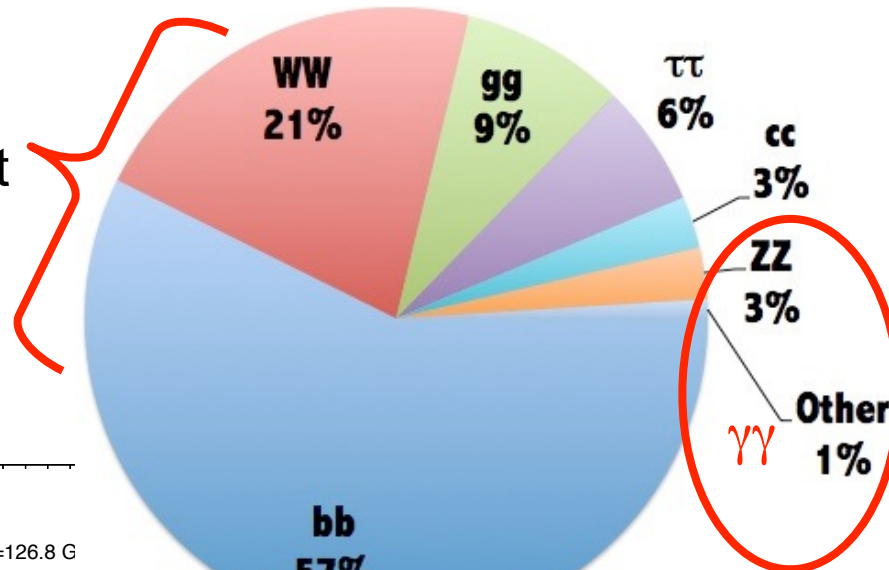

The main  
discovery  
channels

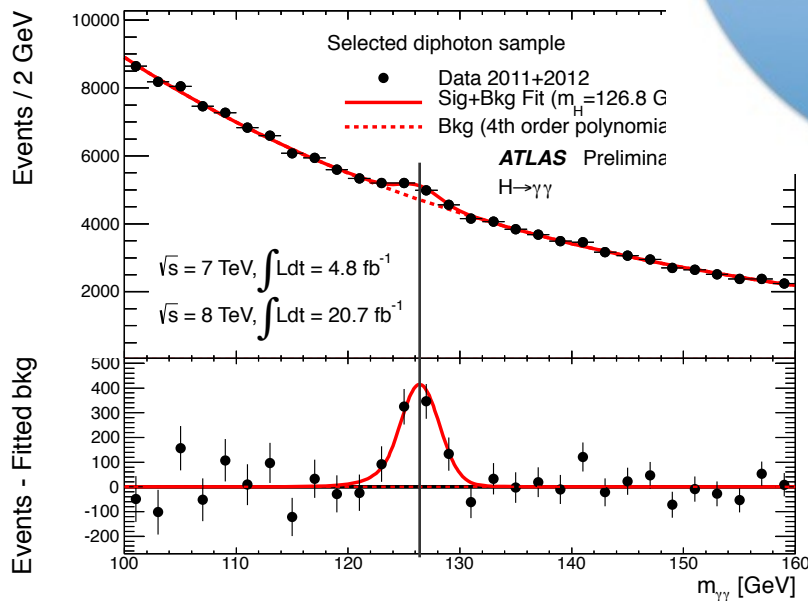

Question: why ?

Hint: background,  
detector resolution

# Measurements of Higgs' behavior at the LHC

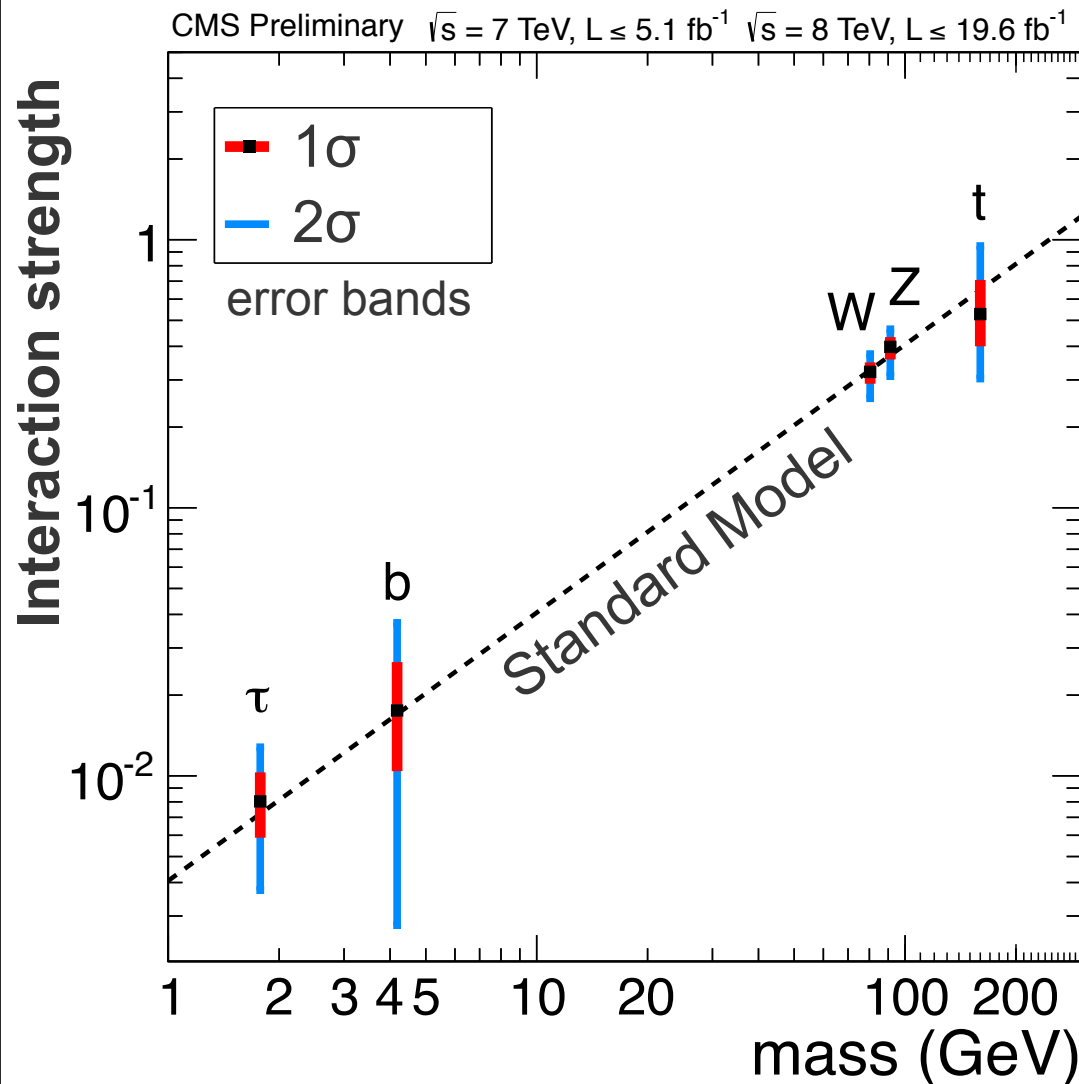

- It couples to other particles **proportionally to their masses**
- If couplings didn't have this pattern, **it would indicate that not all mass comes from a single Higgs**
- Aim to shrink the error bars
- There could be one or more “large”  $\sim 10\%$  deviations

# What the observed Higgs hasn't answered yet

We have discovered a boson that couples to other heavy particles proportionally to their masses.

Hence “Standard Model like”

**Question:** is this the fundamental particle related to breaking of the symmetry of the electroweak force?

- Or just one member of the Higgs family ?
- Any underlying physics behind its mass ?

**Answer:** We do not know yet, but can

- a) search for additional Higgs bosons
- b) probe processes sensitive to symmetry breaking



# Outline

- ▶ Higgs boson discovery
- ▶ Its measurements at the LHC
- Probes of new physics in broken symmetry**
- ▶ Summary

# Search for additional Higgs boson

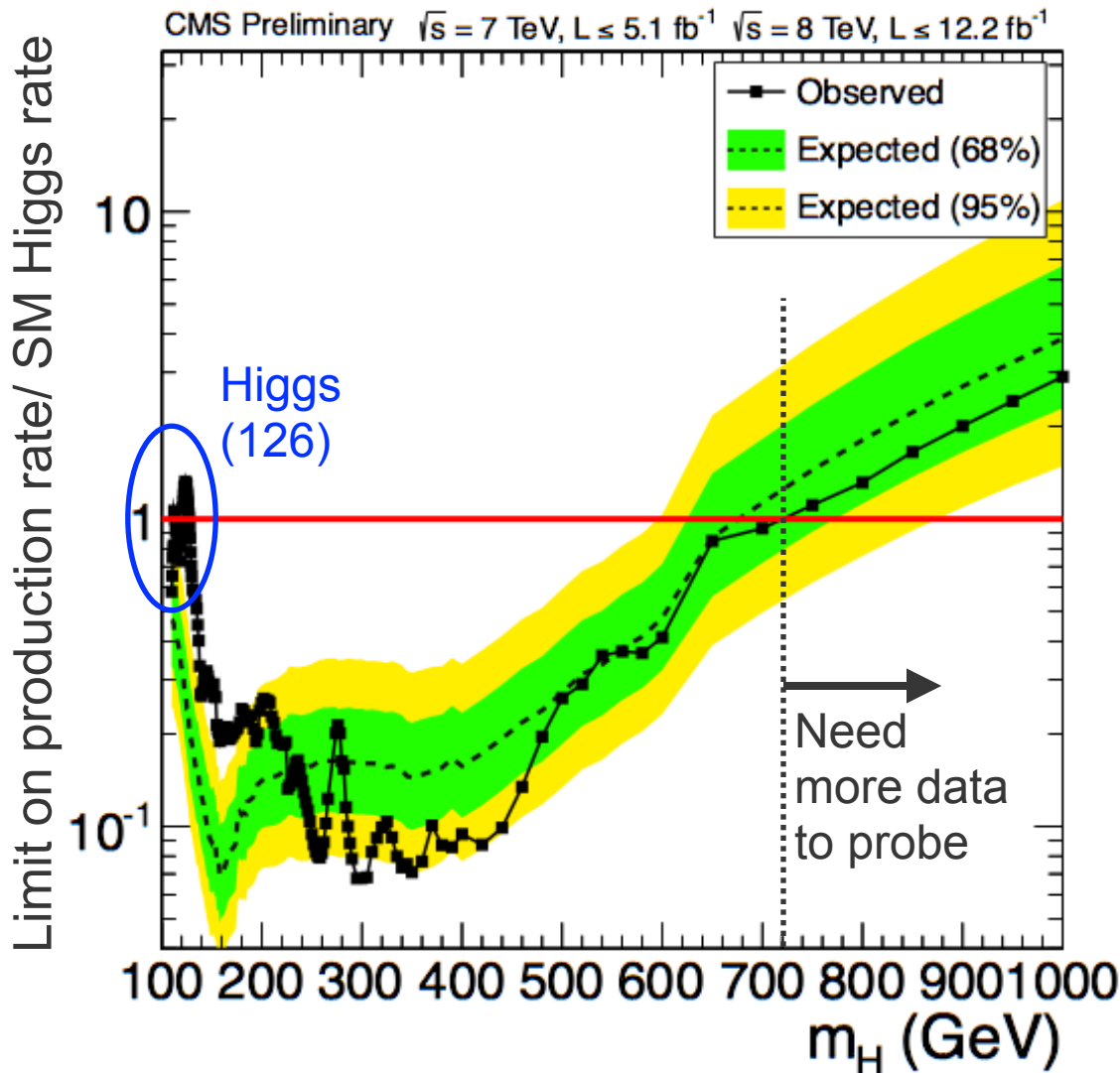

- Search including all WW and ZZ channels
  - I've been closely involved with this
- No additional Higgs states up to 700 GeV
- Interesting territory  $> 700$  GeV yet to probe

# Processes sensitive to symmetry breaking

WW production

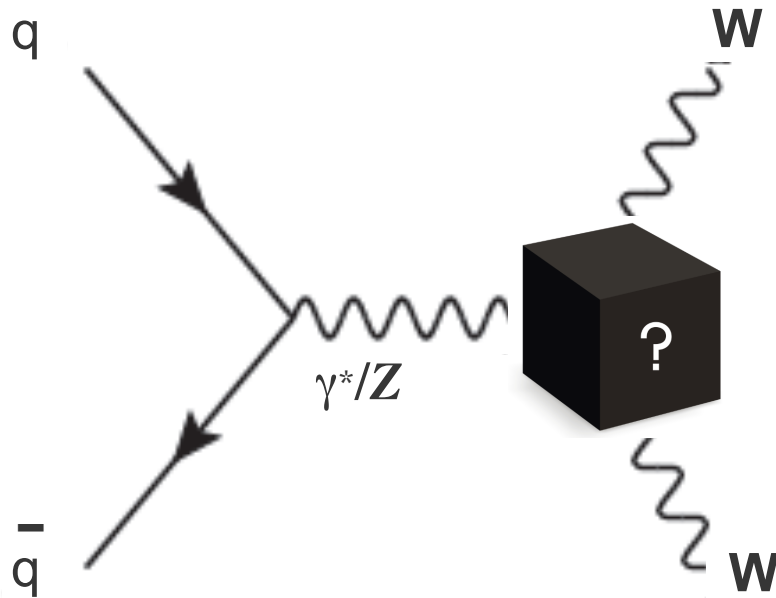

Is there a structure hidden inside the black-box ?

# Understanding W boson interaction

in semi-classical theory

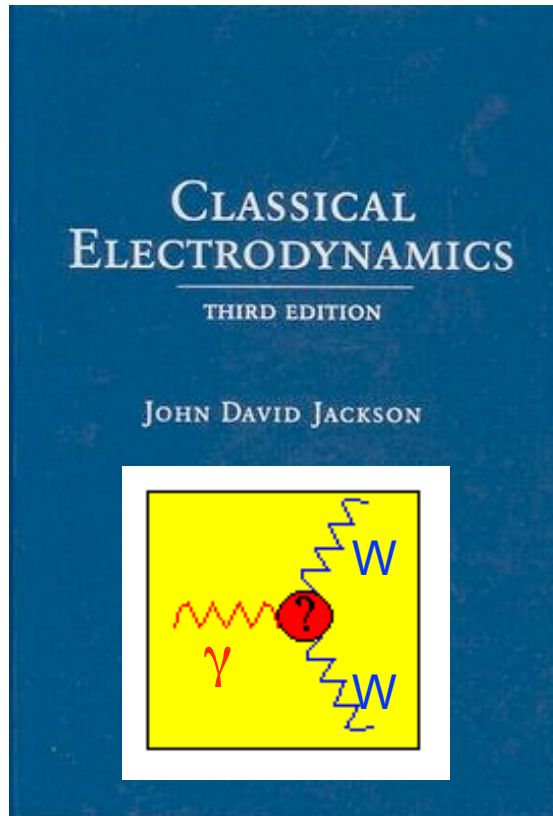

► Interaction between W and e.m. field completely determined by 3 numbers:

- W's electric charge  $1/r^2$

- W's magnetic dipole moment  $1/r^3$

- W's electric quadrupole moment  $1/r^4$

Exactly 0 in the Standard Model

Sensitivity to new physics is at short distances/ high energy

# In quantum field theory ...

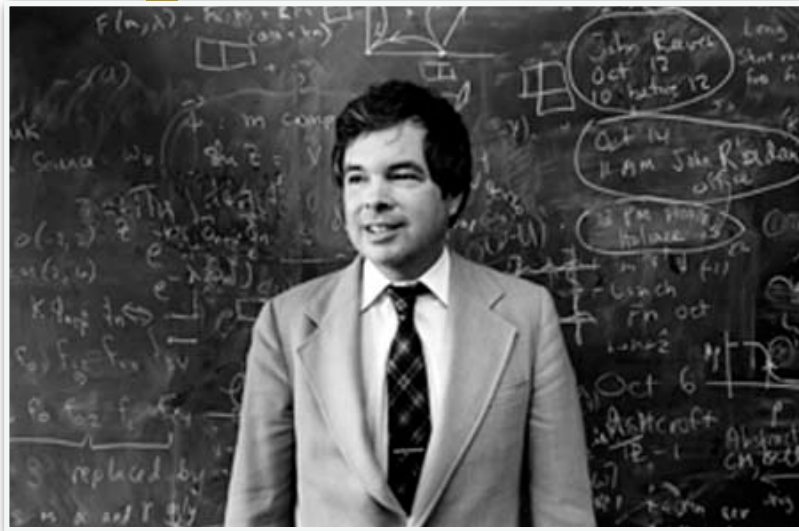

**Ken Wilson (1936–2013)**  
Nobel prize 1982

## Wilsonian approach

That which is not forbidden is required:

(Murray Gell-Mann's totalitarian principle)

include all interactions consistent with space-time, global symmetries

Data = SM + **Correction from new physics**

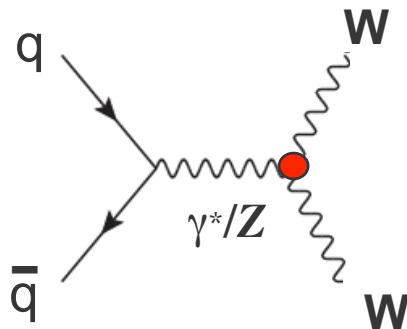

$$L = g(W_{\mu\nu}^\dagger W^\mu A^\nu - W_\mu^\dagger A_\nu W^{\mu\nu}) + (1 + \Delta\kappa_\gamma)(W_\mu^\dagger W_\nu F^{\mu\nu}) + \frac{\lambda_\gamma}{M_W^2}(W_{\rho\mu}^\dagger W_\nu^\mu F^{\nu\rho})$$

(with)  
 $W_{\mu\nu} = \partial_\mu W_\nu - \partial_\nu W_\mu - gW_\mu \times W_\nu$

- + three similar terms for the Z
- + nine other terms that do evil things (violate CP and/or EM gauge invariance)

# Connecting the two together

Dipole and quadrupole moments of W boson

$$\mu_W = e \frac{2 + \Delta\kappa_\gamma + \lambda_\gamma}{2M_W}$$

$$Q_W = -e \frac{1 + \Delta\kappa_\gamma - \lambda_\gamma}{M_W^2}$$

Jackson 3rd ed, Eq. 5.59

We probe their deviation from 0

Analogy: muon's magnetic moment “g-2”

$$a_\mu^{expt} = 0.00116592080(63)$$

$$a_\mu^{Theo} = 0.00116591841(48)$$

**3 $\sigma$  discrepancy**

# Experimental signature I work on

Study of WW production

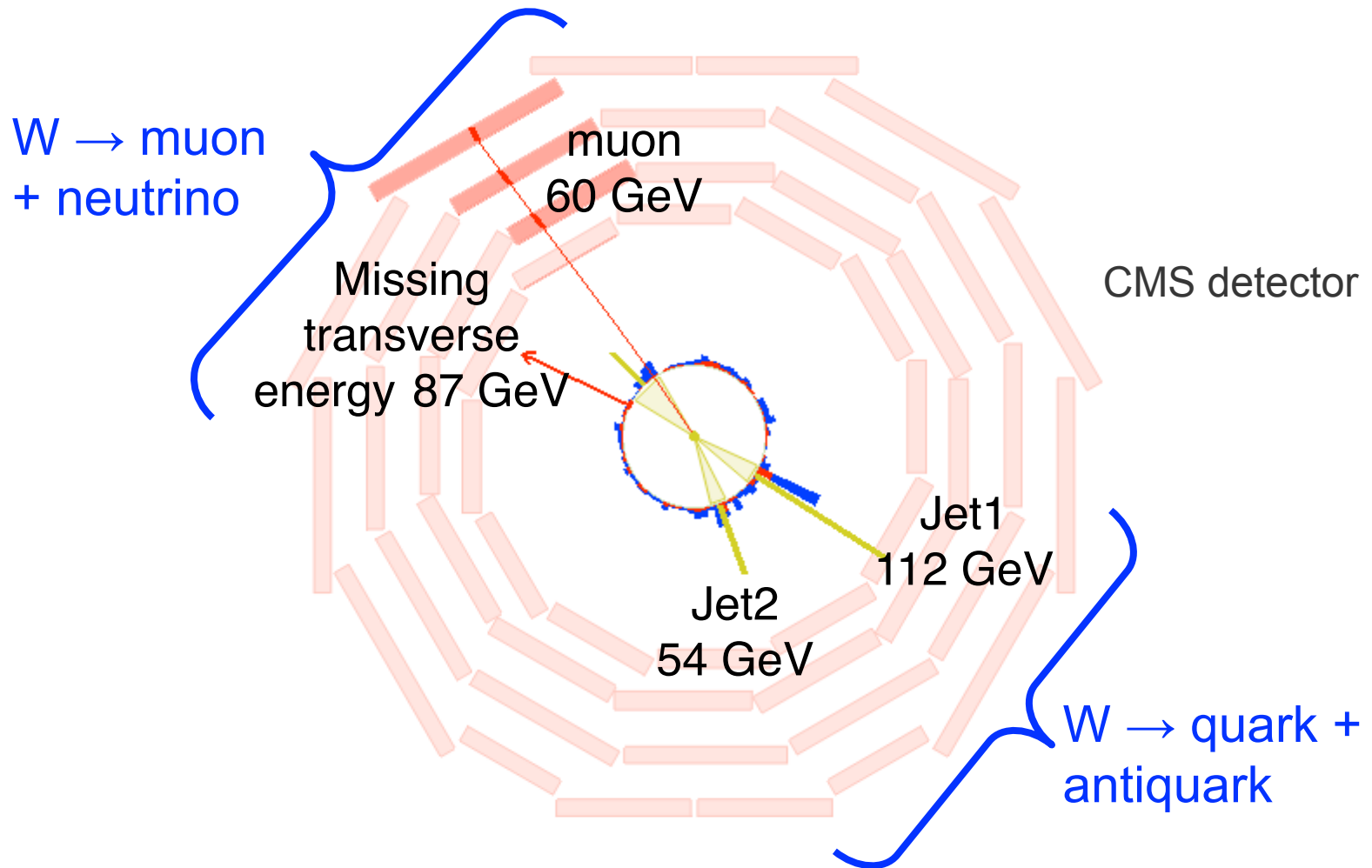

# Measurement in data

W boson energy is the observable

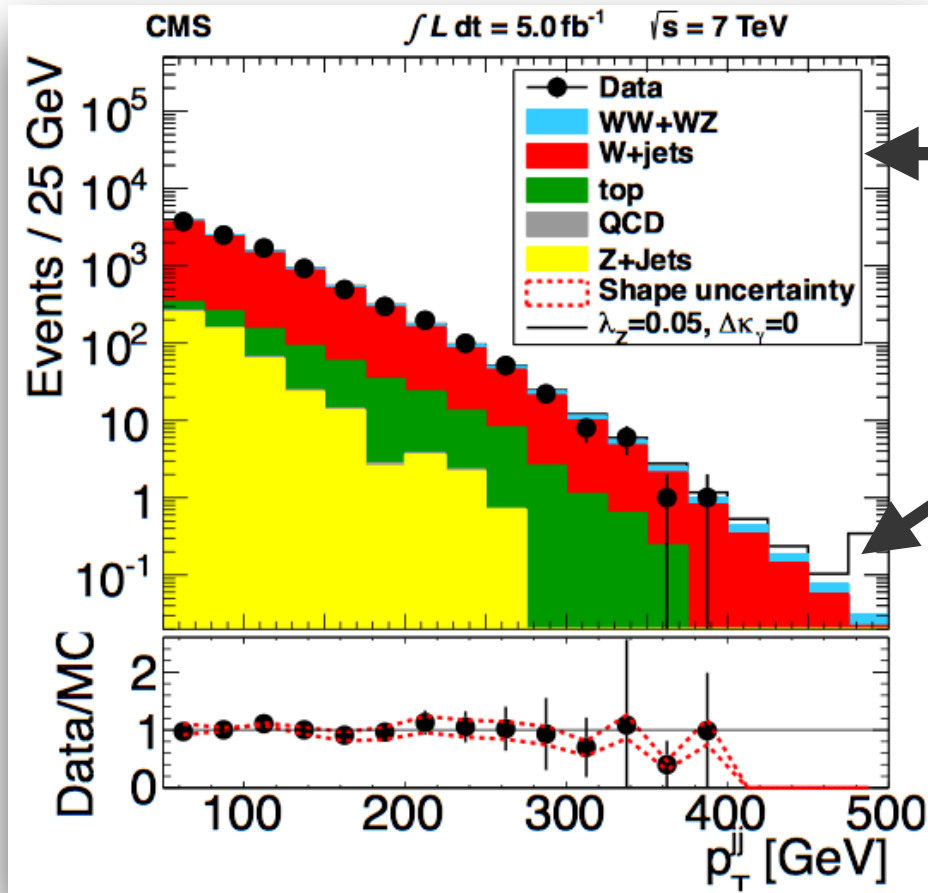

Various backgrounds shown in different colors.

New physics could show up here.

Dipole moment of W constrained at **1% level**, quadrupole moment at **0.01% level**.

⇒ No structure inside the blackbox so far

# The question for the next LHC run

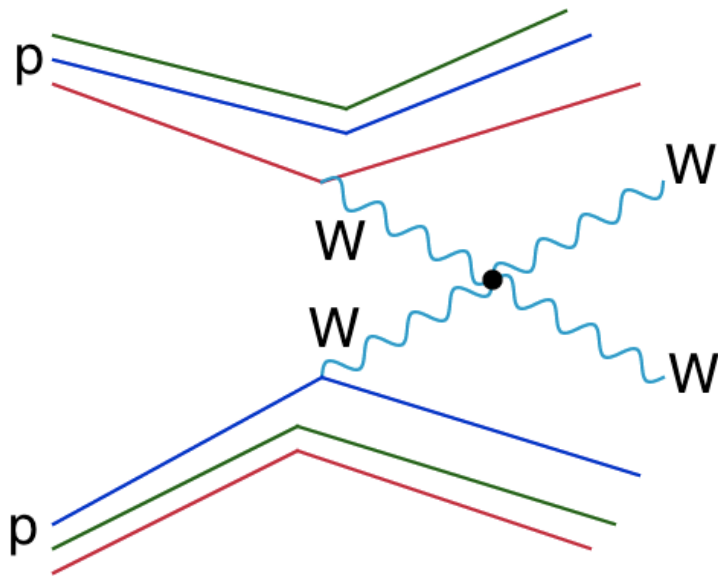

This diagram can test the breaking point of the Standard Model

Standard Model predicts that at high energies without something Higgs-like, this process should occur with a probability **> 100 % !!!!**

- Is it a problem, or just an illusion, or we have found THE Higgs boson ?
- 14 TeV data will tell us

# The LHC 14 TeV program

Current data size  $\approx 25 \text{ fb}^{-1}$  at 7/8 TeV

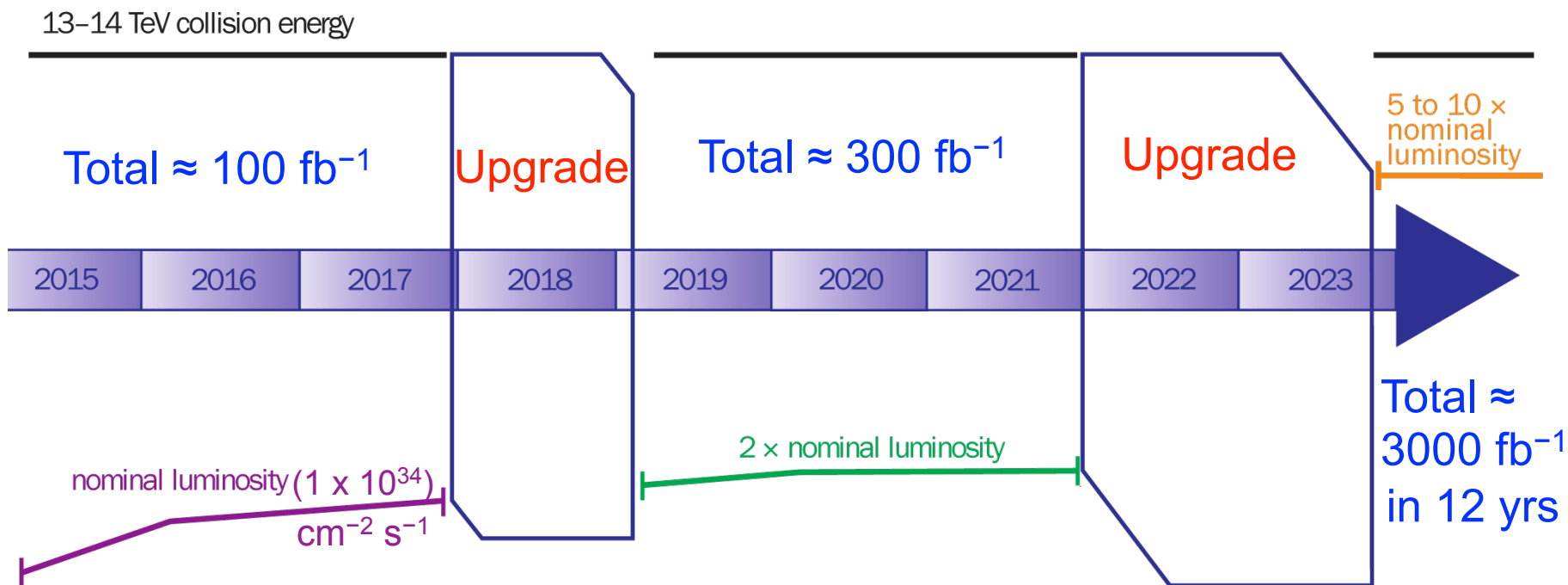

# Outline

- ▶ Higgs boson discovery
- ▶ Its measurements at the LHC
- ▶ Probes of new physics in broken symmetry
- Summary**

# Summary

One “small” step at the LHC, a giant leap for mankind ...



- ☑ The Higgs discovery is a crucial milestone in our understanding, but is only the beginning of a story
- ☑ We now seek a full understanding of the broken symmetry
  - door to new **underlying physics**
- ☑ Exciting times ahead at LHC 14 TeV

BACKUP SLIDES

# U.S. participation

One of the largest investments of the U.S. in particle physics ever!

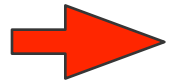

“CERN is the second largest particle physics laboratory of the United States”.

– Rolf Heuer, CERN Director General  
(heard saying in an informal meeting)

## US ATLAS

44 institutions  
376 PhD authors (21%)  
175 students

## US CMS

49 institutions  
426 PhD authors (32%)  
247 students

# Higgs mechanism

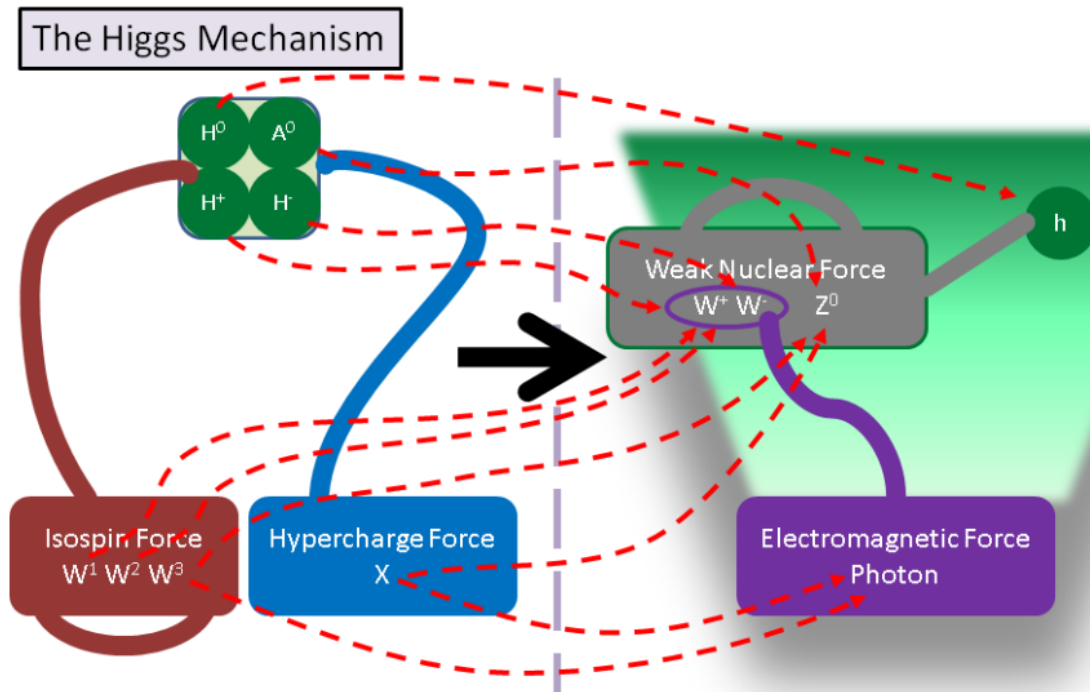

- Higgs field mixes the massless  $W$  and  $X$  force carriers
- making three of them massive
- retaining one Higgs boson

Symmetry of weak force spontaneously broken, Higgs boson the agent.

# Higgs decay to two photons

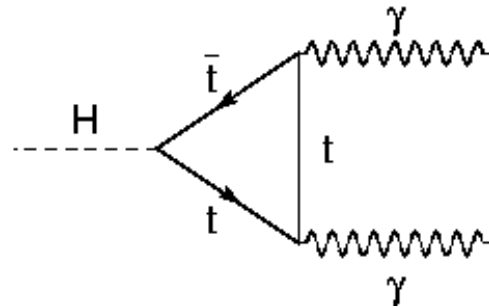
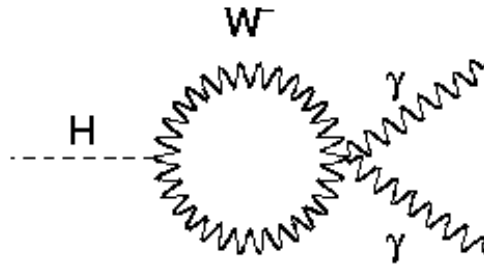
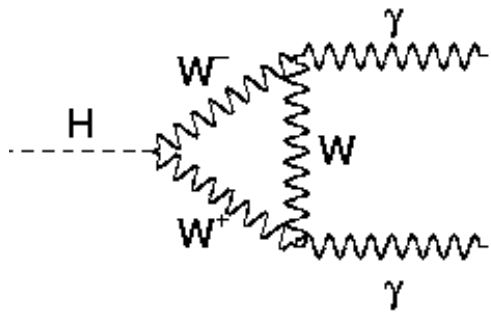

Notice that the W loop diagram dominates, however the top loop diagram has opposite sign. Heavy fermions in the loop can further bring down the rate.

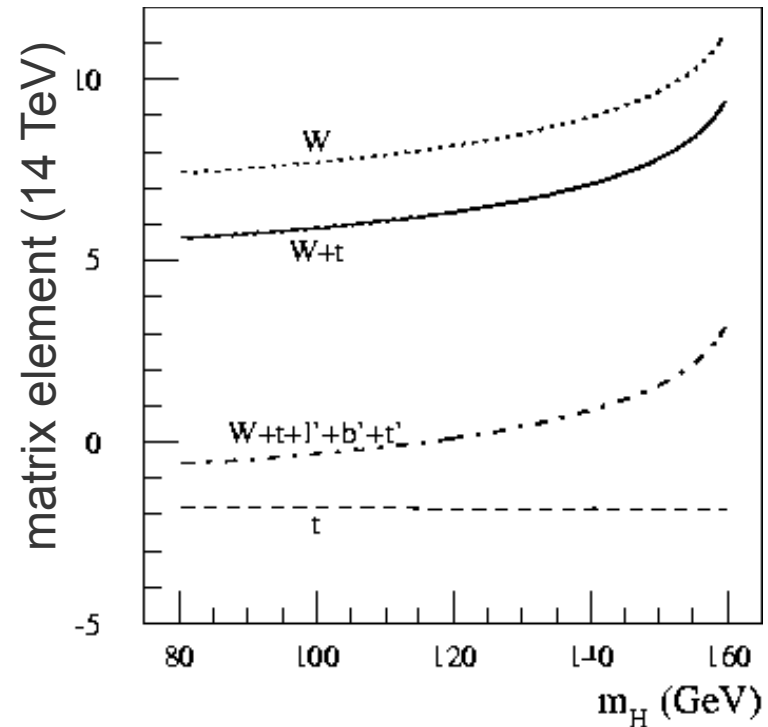

# Fermion masses

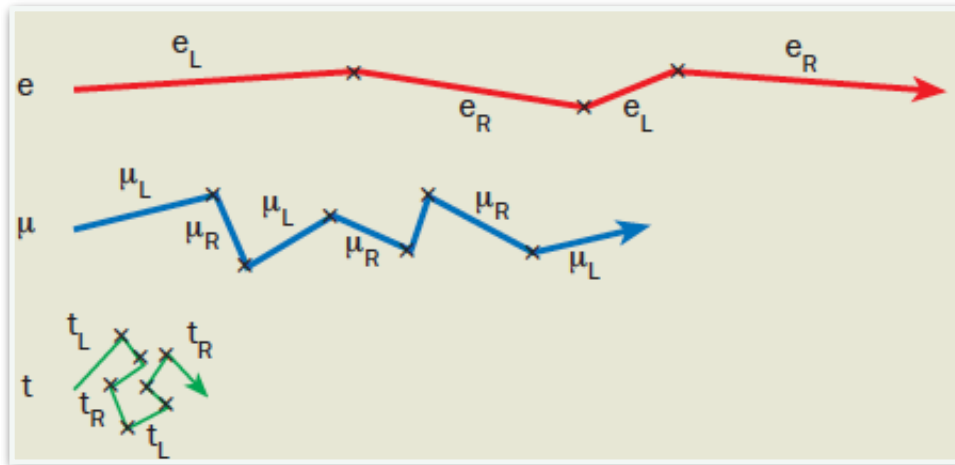

- Matter particles in the “vacuum” acquire mass as they collide with Higgs

Change handedness:

left-handed  $\leftrightarrow$  right-handed

## What about neutrino masses?

Experiments have shown that neutrinos are always left-handed.

Since right-handed neutrinos do not exist in the Standard Model, the theory predicts that **neutrinos can never acquire mass**.

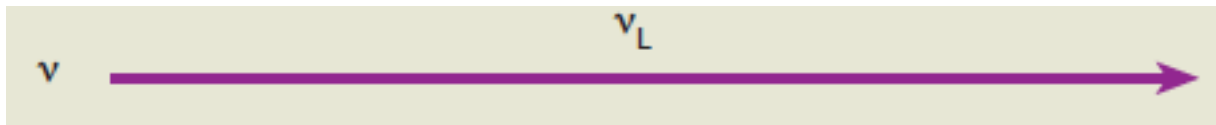

Therefore, the discovery of neutrino mass in itself is **a clear evidence that, at the very least, the SM is incomplete**.

# Possible explanations of the neutrino masses

In one extension to the SM, left- and right-handed neutrinos exist. These Dirac neutrinos acquire mass via Higgs mechanism but right-handed neutrinos interact much more weakly than any other particles.

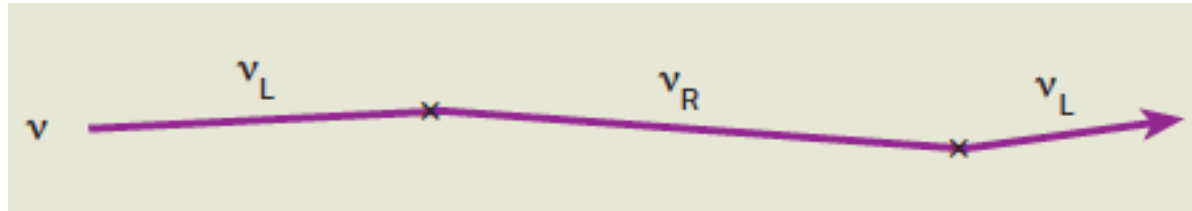

According to another extension of the SM, extremely heavy right-handed neutrinos are created for a brief moment before they collide with the Higgs boson to produce light left-handed Majorana neutrinos.



Other possibilities, e.g., RPV models with two pairs of Higgs doublets

[arXiv:1401.1818](https://arxiv.org/abs/1401.1818)

# Question closely related to the scale problem

Who sets these mass scales?  
How ?

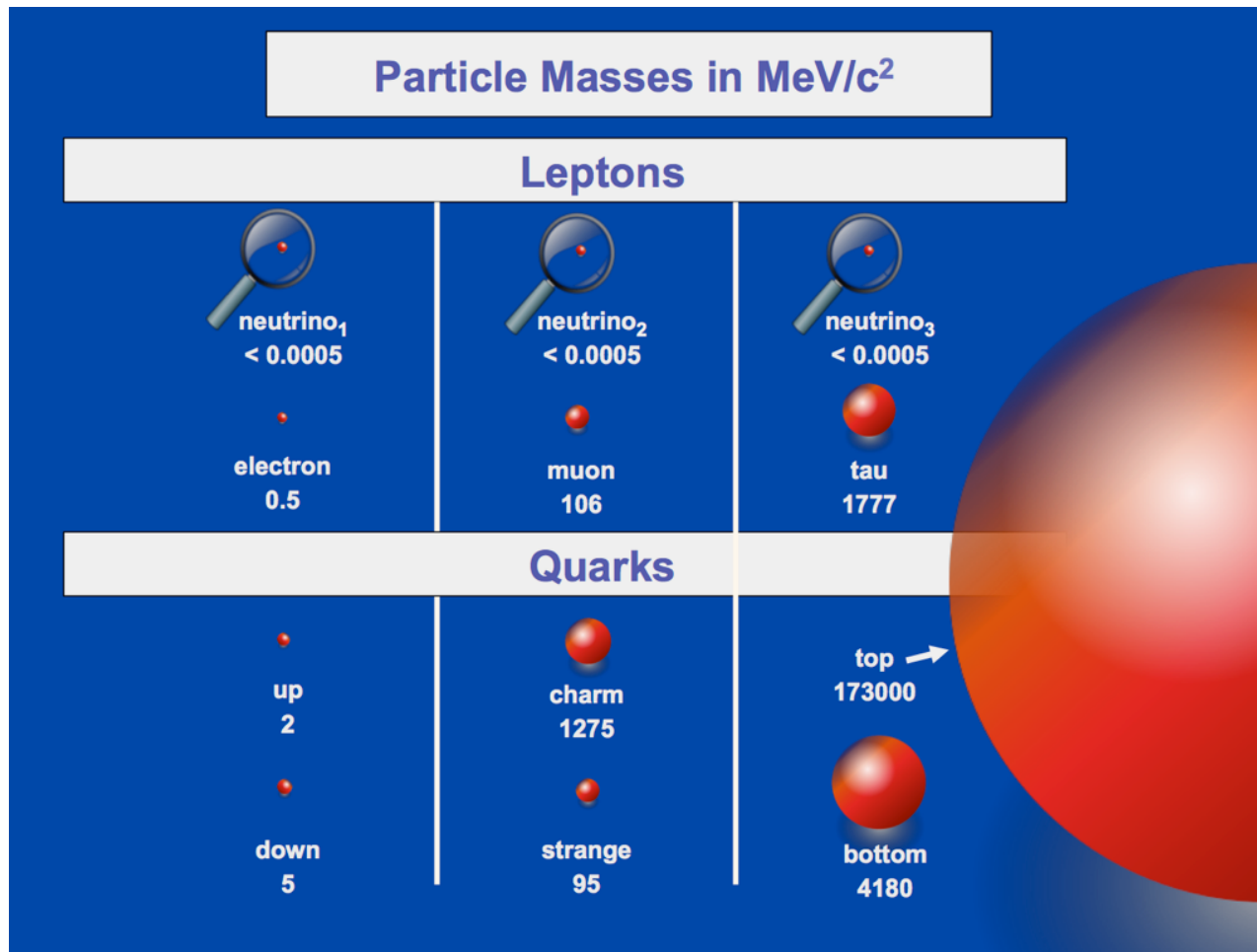

Need new physics beyond the SM to explain these

# Higgs boson observation in a nutshell

For a mass of  $m_H = 125.7 \pm 0.4$  GeV

<b>Decay</b>	<b>Expected</b>	<b>Observed</b>	
<b>ZZ</b>	<b>7.1 <math>\sigma</math></b>	<b>6.7 <math>\sigma</math></b>	
<b><math>\gamma\gamma</math></b>	<b>3.9 <math>\sigma</math></b>	<b>3.2 <math>\sigma</math></b>	bosons
<b>WW</b>	<b>5.3 <math>\sigma</math></b>	<b>3.9 <math>\sigma</math></b>	
<b>bb</b>	<b>2.2 <math>\sigma</math></b>	<b>2.1 <math>\sigma</math></b>	} 3.4 $\sigma$ combined! fermions
<b><math>\tau\tau</math></b>	<b>2.6 <math>\sigma</math></b>	<b>2.8 <math>\sigma</math></b>	

bb: includes VH and VBF, WW: includes ggF, VH, VBF

# In more technical detail ...

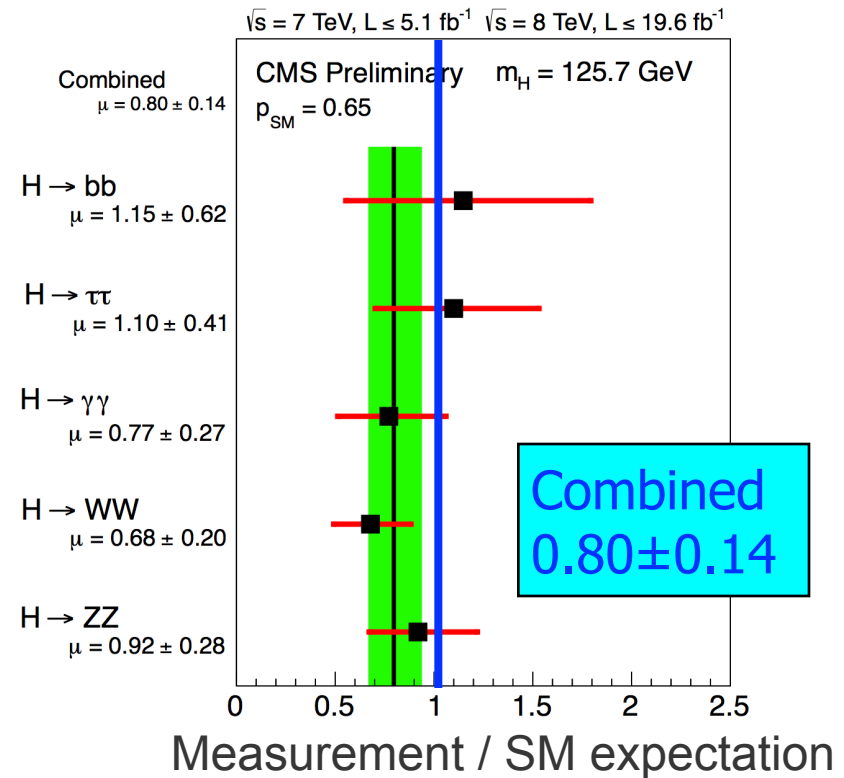
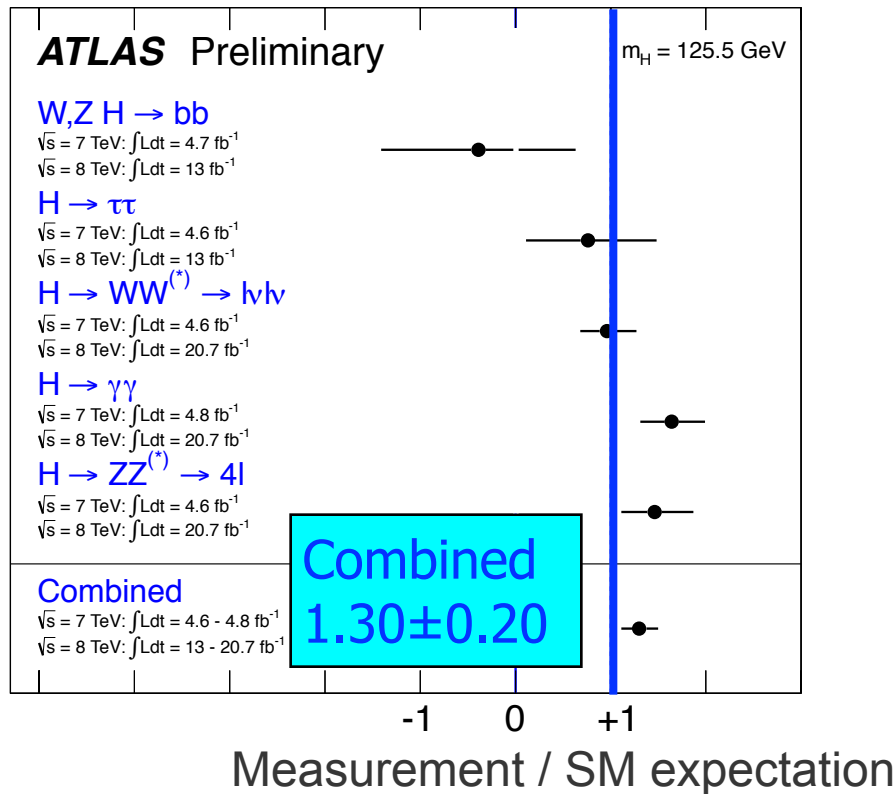

- So far consistent with the Standard Model expectation
- It clearly helps to have two experiments.

# If you know the mass you know ...

## Production and decay rates

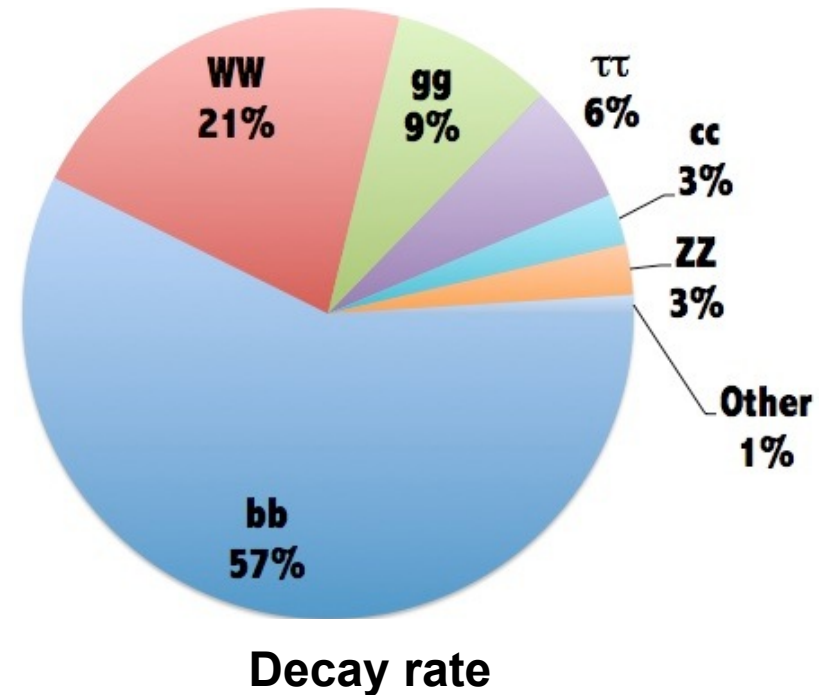
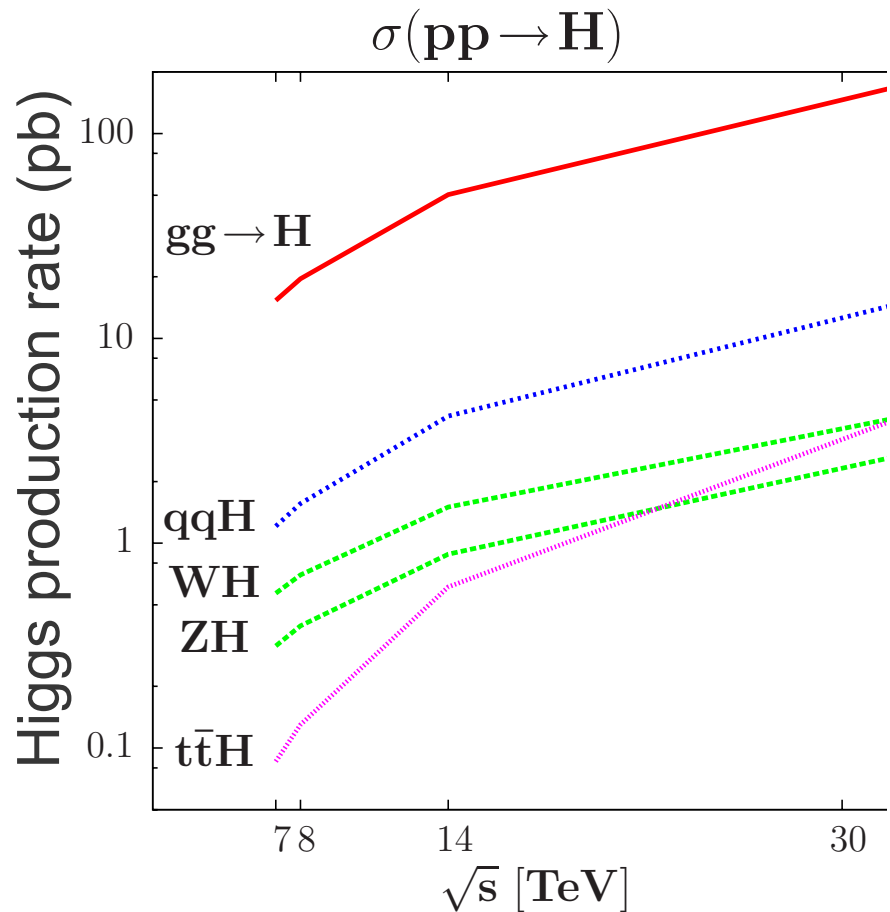

# And its identity

In the Standard Model:  $spin = 0$ , even parity

Observation of Higgs signal already tells us something about spin !

Spin of particle	$\gamma\gamma$	$ZZ^*$	$\tau\tau$	$bb$
Spin 0	😊	😊	😊	😊
Spin 1	😞*	😊	😊	😊
Spin 2	😊	😊	😞	😊
Seen?	Yes	Yes	Yes	~Yes

Also confirmed using angular information of decay products

\*Landau-Yang theorem, but there are caveats

Side note: why spin-2 can decay to  $bb$  but not  $\tau\tau$

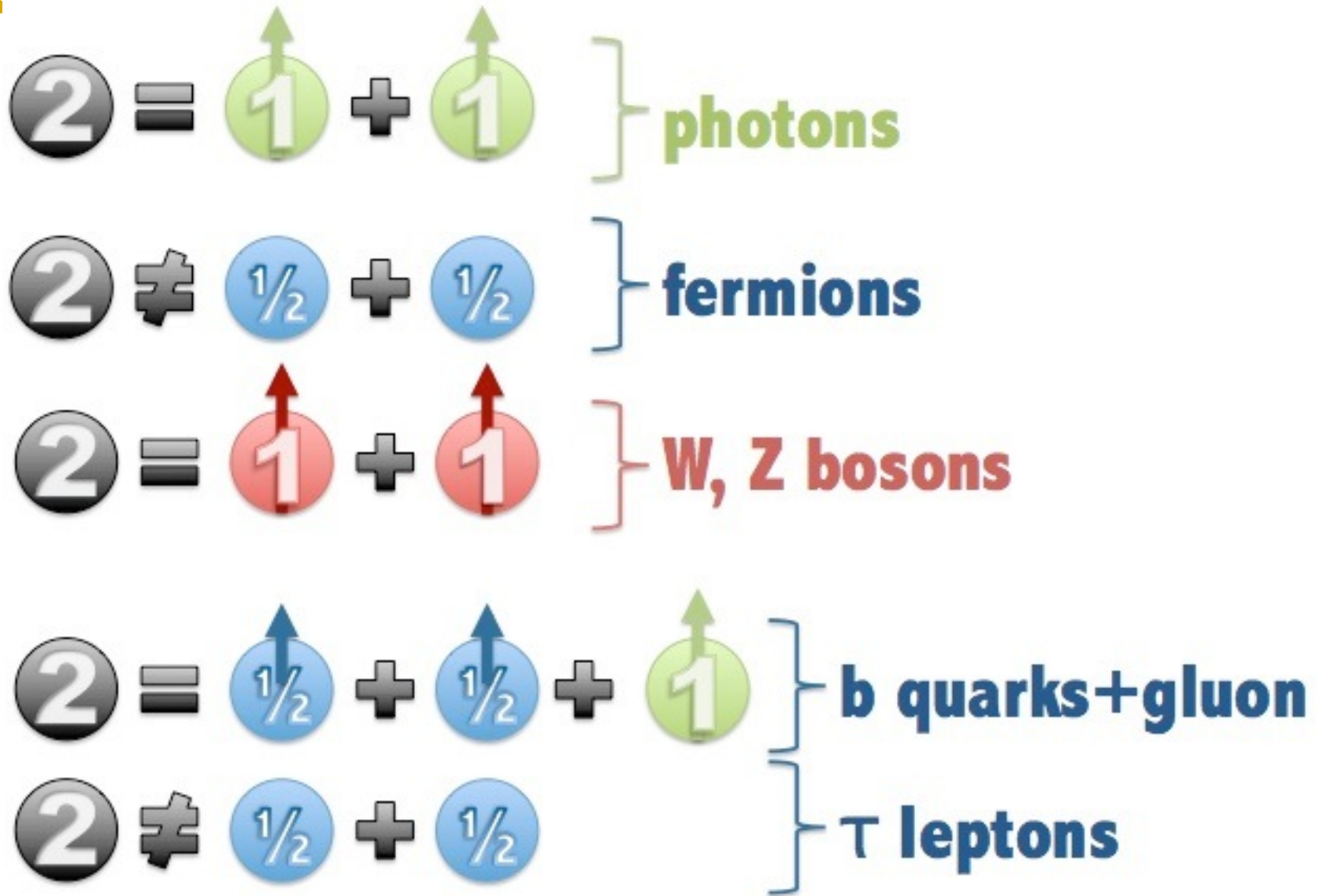

# Detector calibration with early data

Re-established the Standard Model

- known peaks → calibrate detector
- new peak → heralds new discovery

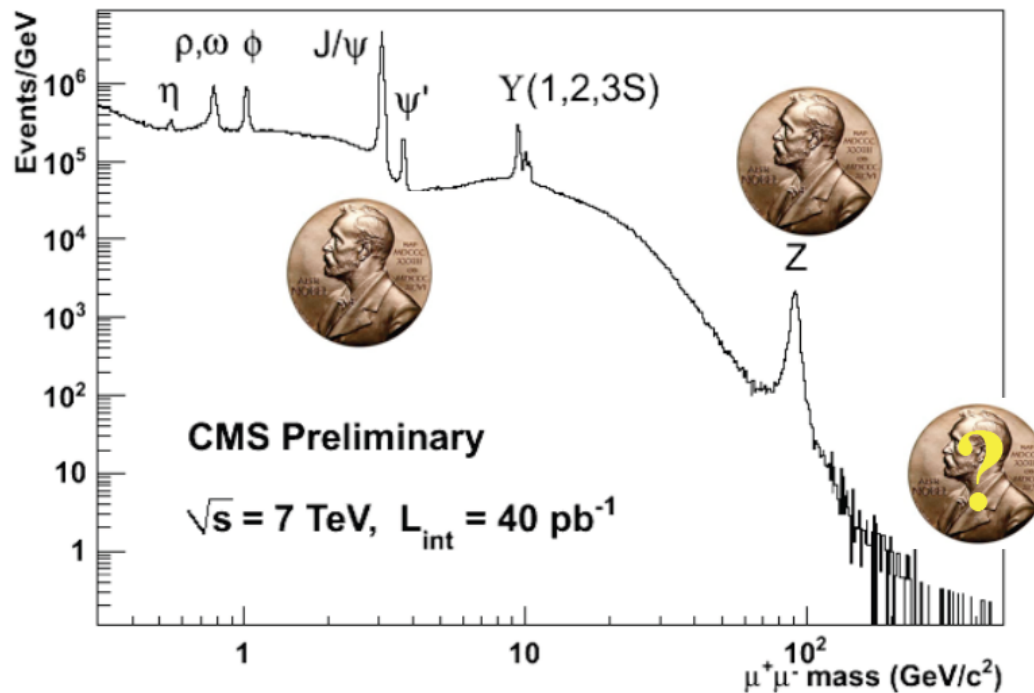

Excellent calibrations of electrons, muons, photons, jets, missing  $E_T$ , b-tag, ...

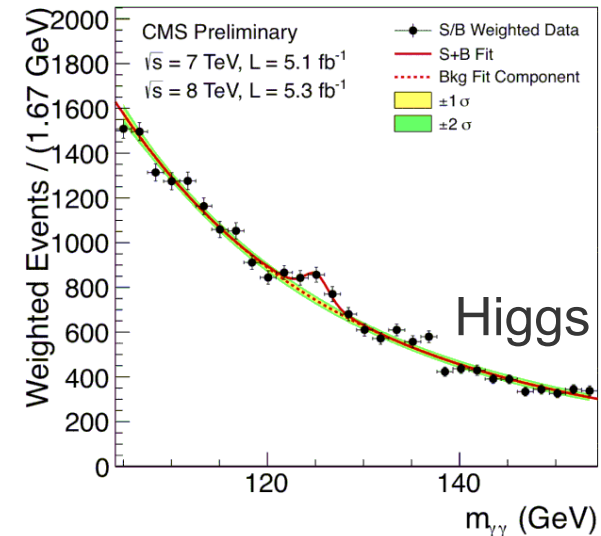
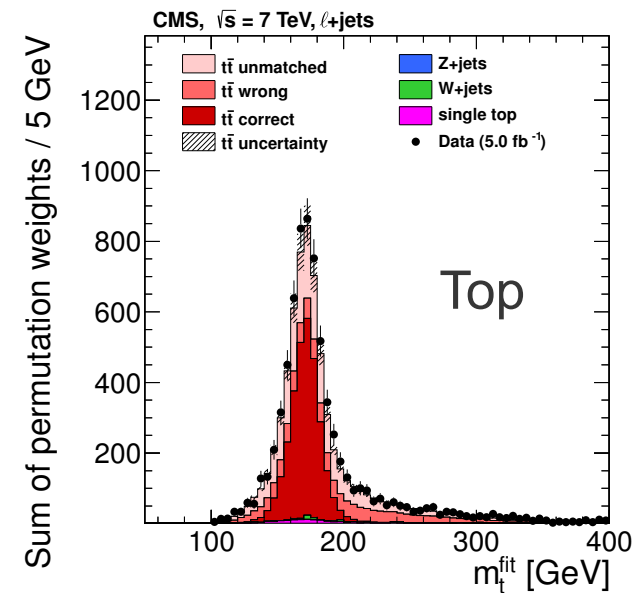

# The Standard Model's breaking point

- While the Standard Model perfectly describes things at low energies, **its predictions at high-energy make no sense.**

Without a Higgs boson

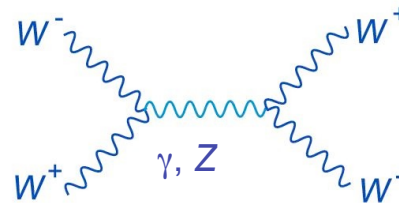

$$= \frac{g^2 E^2}{2m_W^2} (1 + \cos \theta)$$

divergent: SM blows up as  $E^2$

With Higgs boson

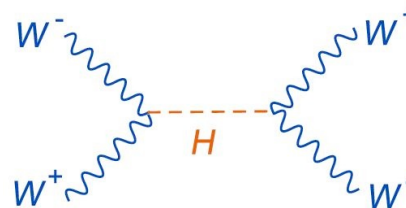

$$= -\frac{g^2 E^2}{2m_W^2} (1 + \cos \theta)$$

no problem now!

- ☑ Rationality is restored when something like the Higgs steps in
  - Is one Higgs enough, does it stop the divergence?
  - Even if it does, a weird fine-tuning! Or some kind of **New Physics**?

# Let's allow heavy Higgs to mix with H(126)

Heavy Higgs mixes with H(126) and modifies its coupling

$$C^2 + C'^2 = 1$$

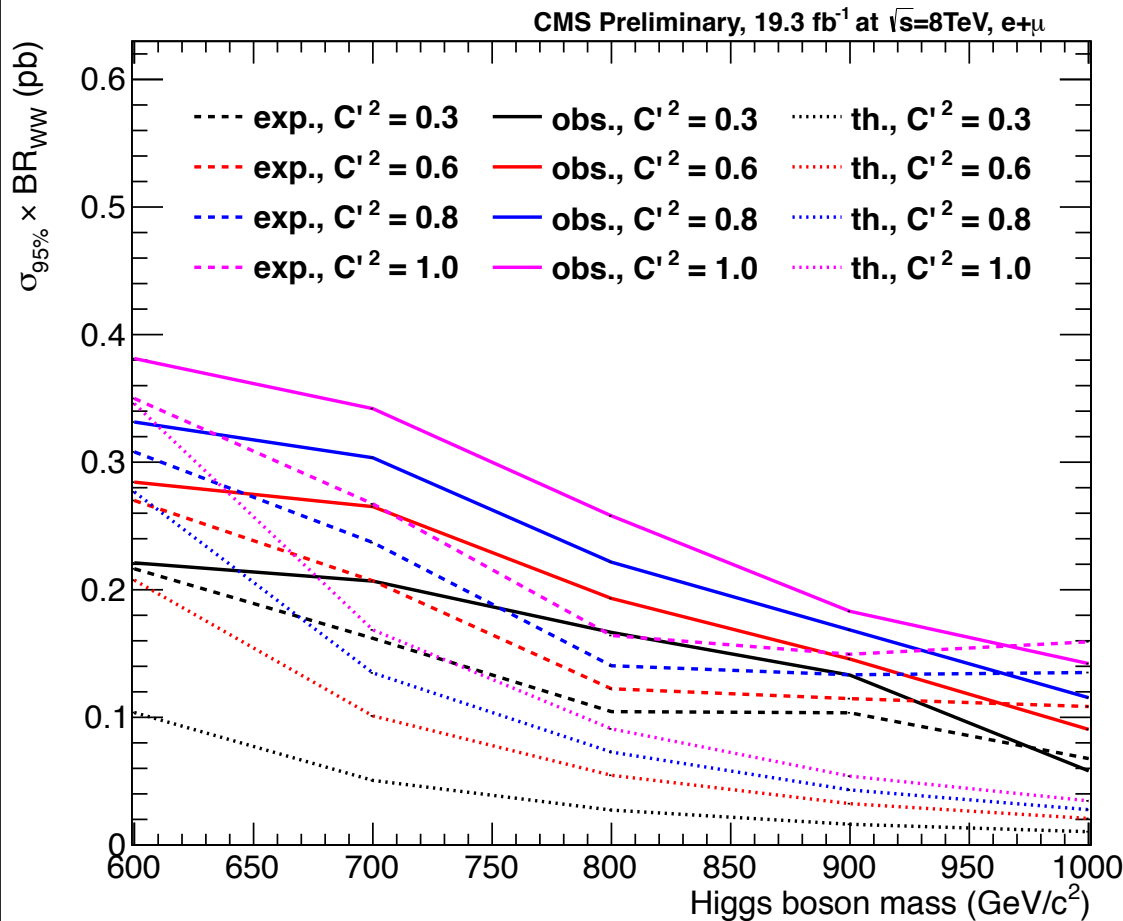

$C'=0 \Rightarrow$  No heavy Higgs state. We only see H(126) tail.

$C'=1 \Rightarrow$  Full contribution from heavy Higgs only.

Typically  $C'^2 > 0.6$  excluded for heavy Higgs  $< 600$  GeV, closing in on 600-1000 GeV.

# Enough events to measure spin-parity

In  $H \rightarrow ZZ^*$  full final state reconstruction sensitive to  $J^P$

- 2 masses ( $M_{Z1}, M_{Z2}$ ), 5 angles
- Form a matrix-element based discriminant

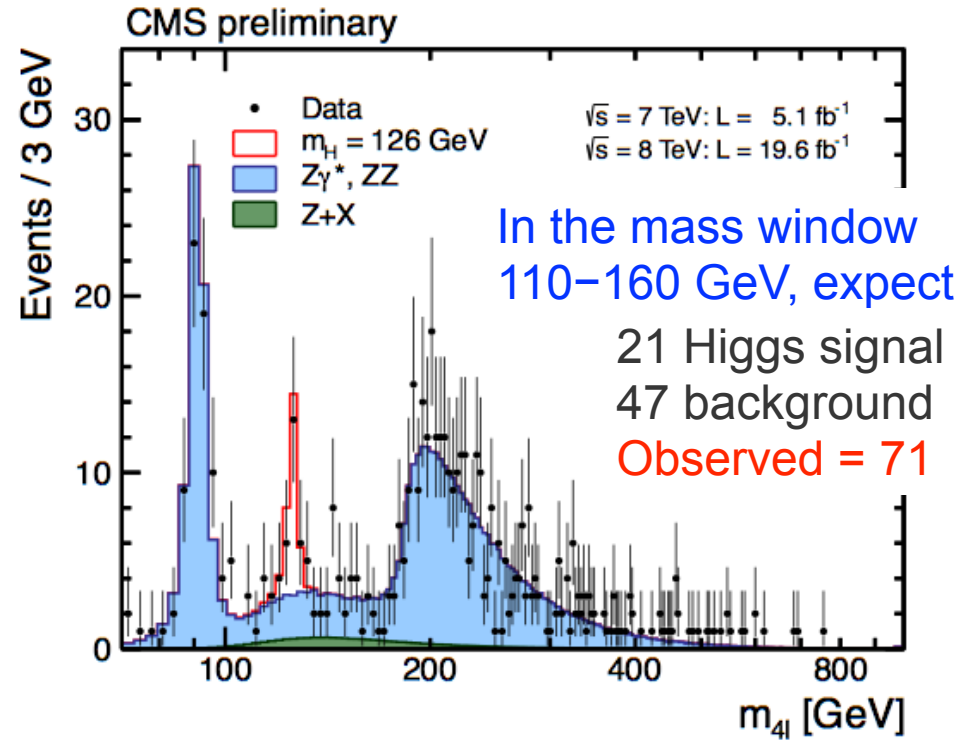
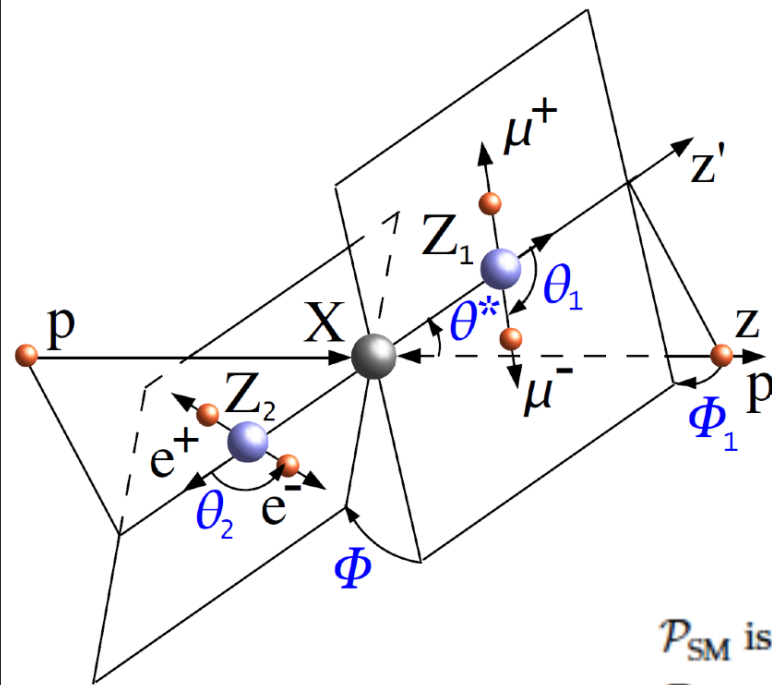

$$\mathcal{D}_{J^P} = \frac{\mathcal{P}_{\text{SM}}}{\mathcal{P}_{\text{SM}} + \mathcal{P}_{J^P}} = \left[ 1 + \frac{\mathcal{P}_{J^P}(m_{Z1}, m_{Z2}, \vec{\Omega} | m_{4\ell})}{\mathcal{P}_{\text{SM}}(m_{Z1}, m_{Z2}, \vec{\Omega} | m_{4\ell})} \right]^{-1}$$

$\mathcal{P}_{\text{SM}}$  is the probability distribution for the SM Higgs boson hypothesis,  
 $\mathcal{P}_{J^P}$  is the probability distribution for an alternative model.

# Have also measured spin-parity explicitly

More  $J^P$  hypotheses have been tested in a similar way

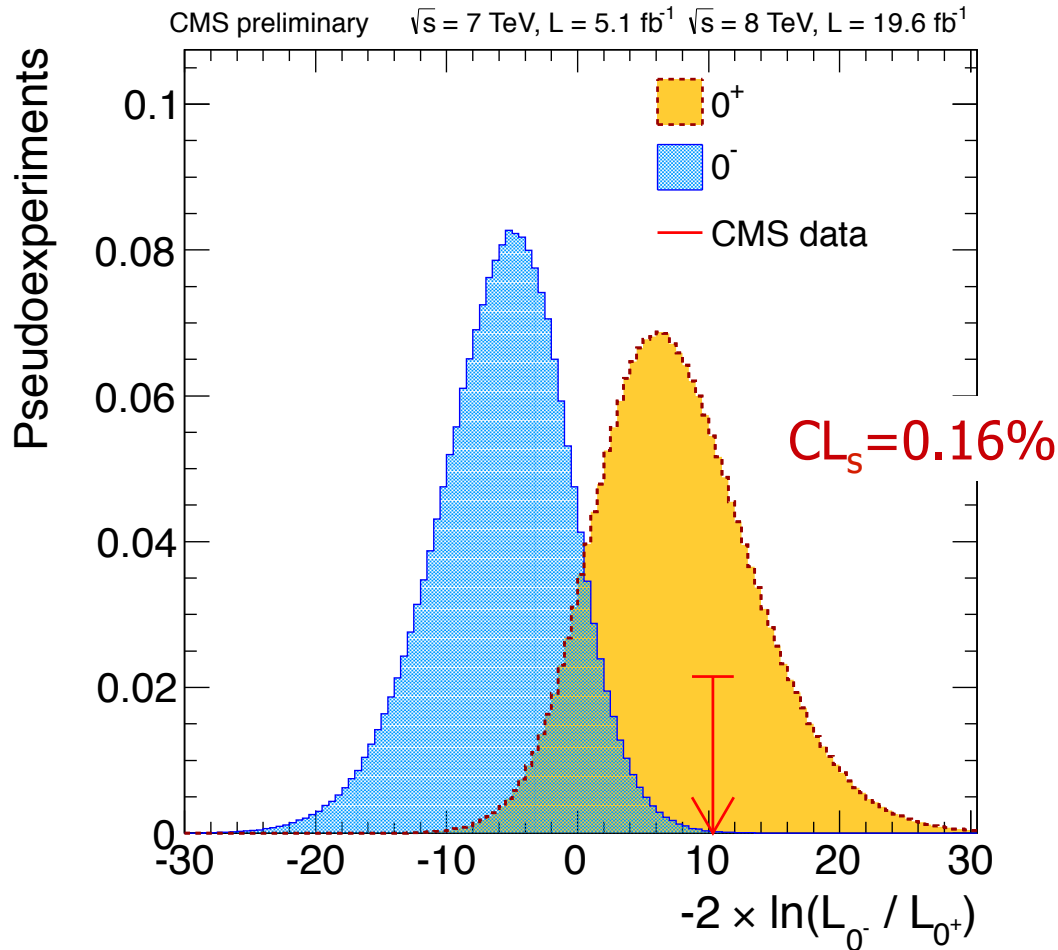

$J^P$	$CL_s$
$0^-$	0.16%
$0^+$	8.1%
$2^+_{m\bar{g}g}$	1.5%
$2^+_{mq\bar{q}}$	<0.1%
$1^-$	<0.1%
$1^+$	<0.1%

Evidence for scalar nature  $0^+$  but CP admixture not completely excluded

# Interesting Q: how much CP odd allowed by data?

Measure **fraction of CP-violating** contribution

Most general spin-0  $H \rightarrow VV$  amplitude

$$A = v^{-1} \left( \underbrace{a_1 m_Z^2 \epsilon_1^* \epsilon_2^*}_{\text{green}} + a_2 f_{\mu\nu}^{*(1)} f^{*(2),\mu\nu} + \underbrace{a_3 f_{\mu\nu}^{*(1)} \tilde{f}^{*(2),\mu\nu}}_{\text{red}} \right)$$

$$= \underbrace{A_1}_{\text{green}} + A_2 + \underbrace{A_3}_{\text{red}}$$

At LO, SM  $a_1 = 1$ ,  $a_2 = a_3 = 0$

$A_3$  : CP odd amplitude

Fit for  $f_{a_3} = |A_3|^2 / |A_1|^2 + |A_3|^2$

- check presence of CP violation (assume  $a_2=0$ , interference term negligible)

$$f_{a_3} = 0.00^{+0.23}_{-0.00}$$

$$f_{a_3} < 0.58 \text{ @95\%CL}$$

$2\Delta \ln L$

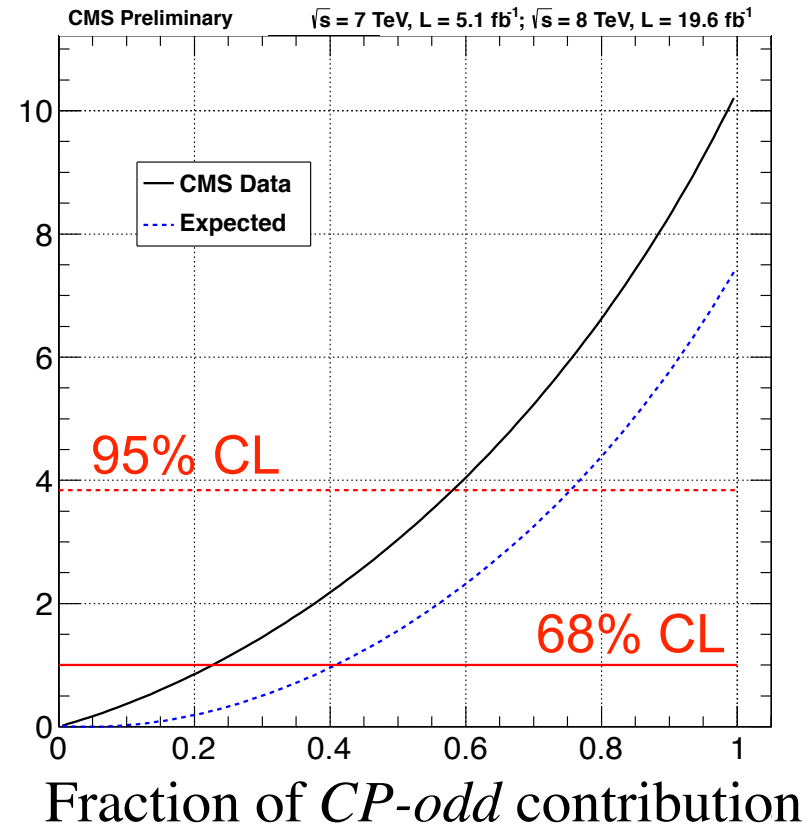

# Any CP violation in Higgs sector?

Significant **CP odd contribution** allowed by current data

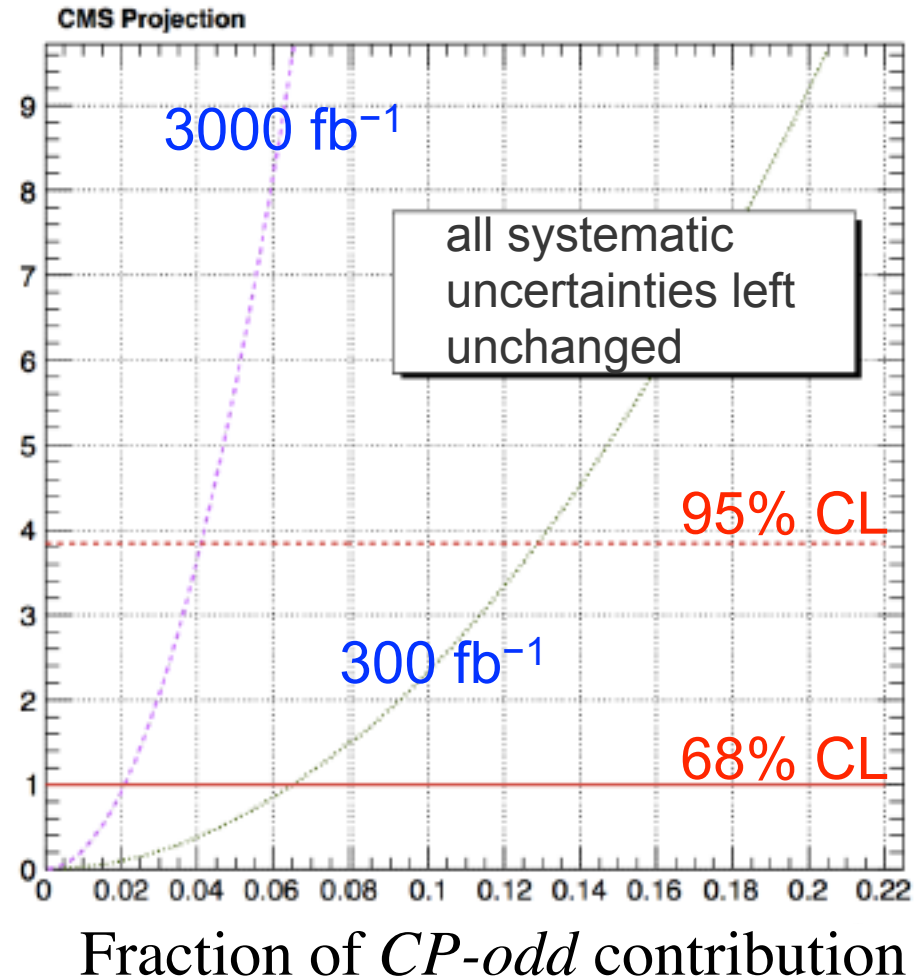
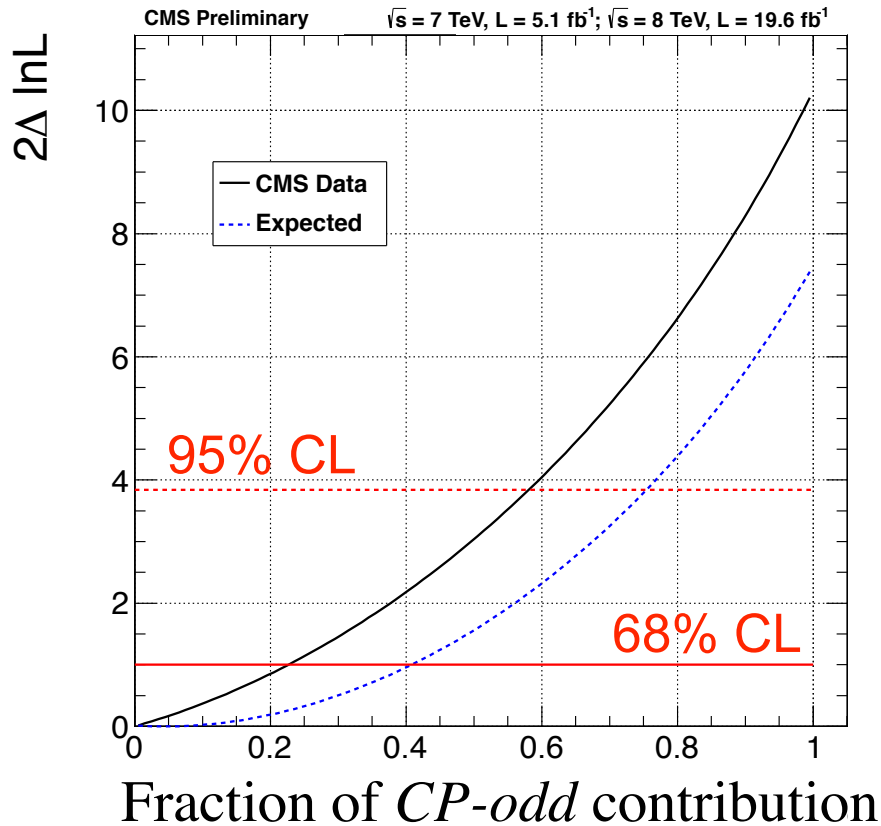

**CP violation probe down to 1–10% possible by 2017–20**

# Search for high mass Higgs states

Why in *this* final state? It wasn't planned in the ATLAS/CMS TDR!

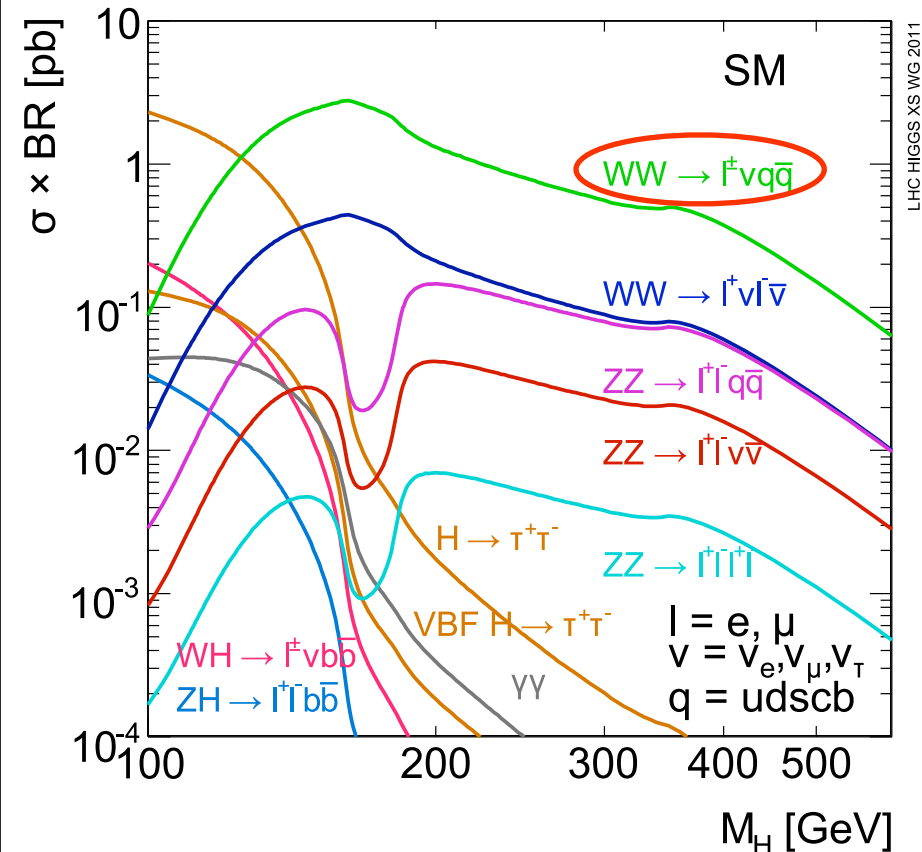

▶  $H \rightarrow WW \rightarrow \ell \nu q \bar{q}$  has the largest production rate over most of the mass range

☑ Using W mass constraint, the decay is sufficiently reconstructed to **produce a mass peak**

▶ Principal drawback is the large W + jets background

- Employ data-driven techniques to understand and control this process.

***The main thrust of the analysis is to model this background well.***

# But have very small production rate

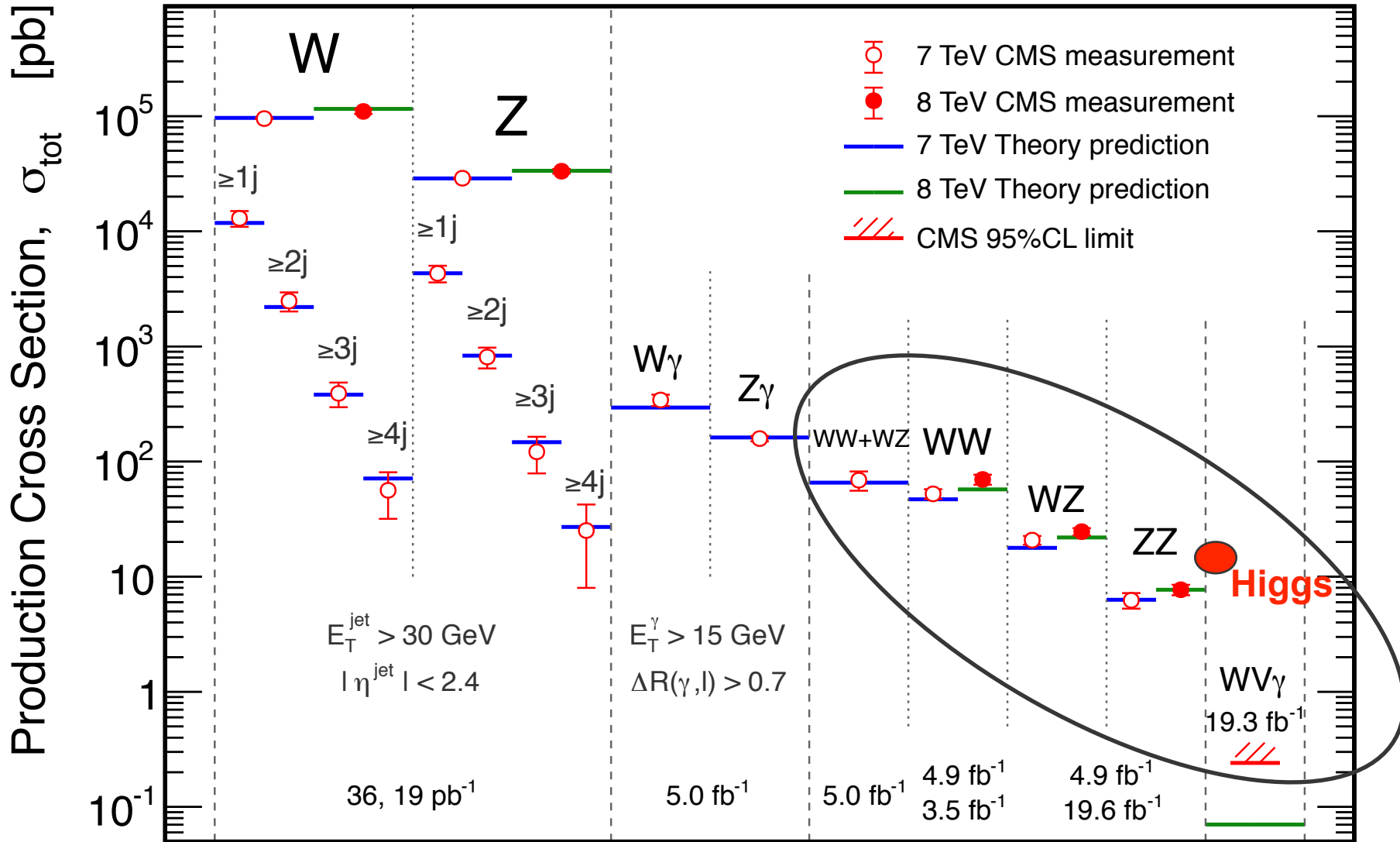

# Reconstructing $W$ or $Z \rightarrow q\bar{q}$

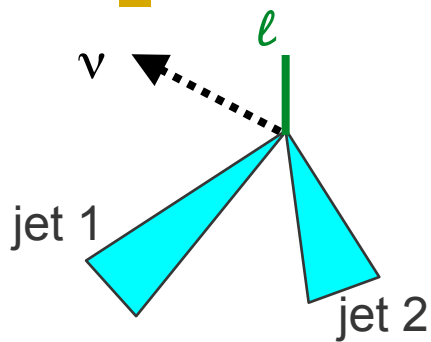

- Establish presence of  $WW+WZ$  in such events
- Jet resolution doesn't allow to cleanly separate  $WW$  from  $WZ$ , so get admixture of the two

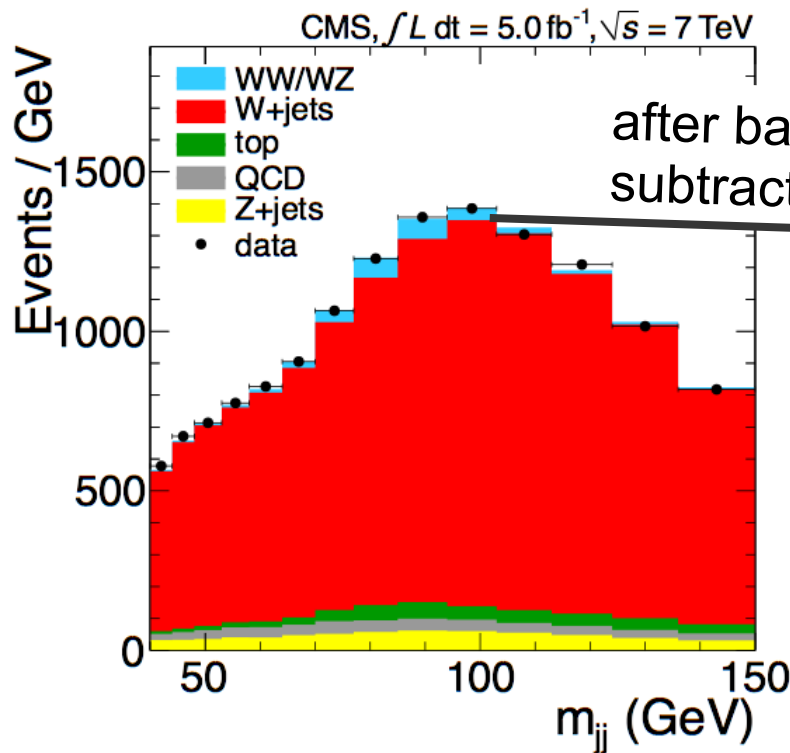

after background subtraction

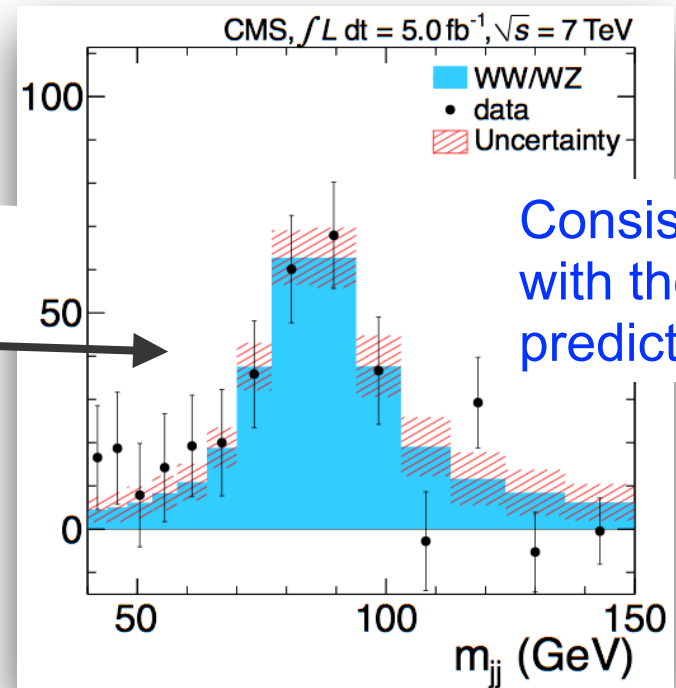

Consistent with the SM prediction

The first observation of diboson in semi-leptonic channel at LHC.

# Now probe WW invariant mass spectrum

<https://twiki.cern.ch/twiki/bin/view/CMSPublic/PhysicsResultsHIG>

CMS HIG-12-046, HIG-13-008

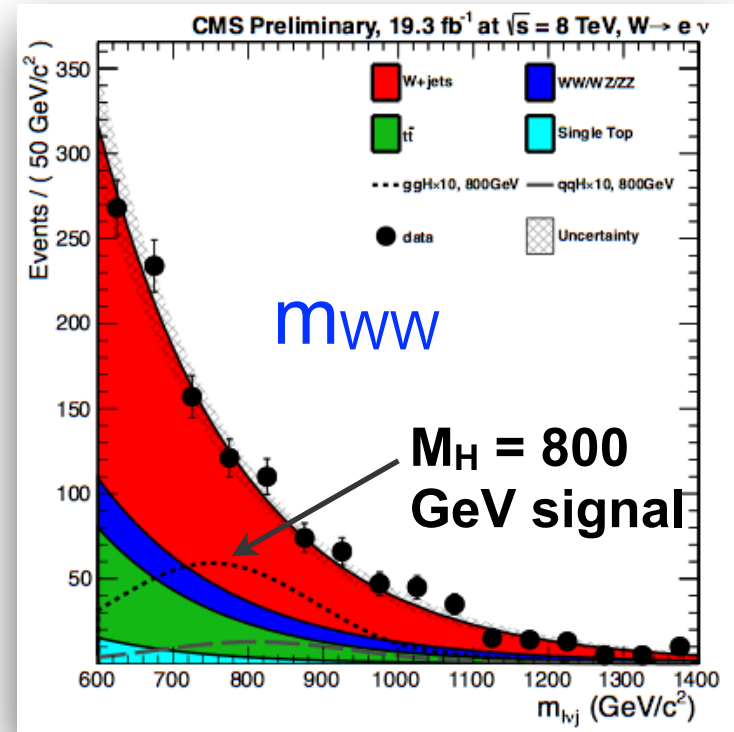
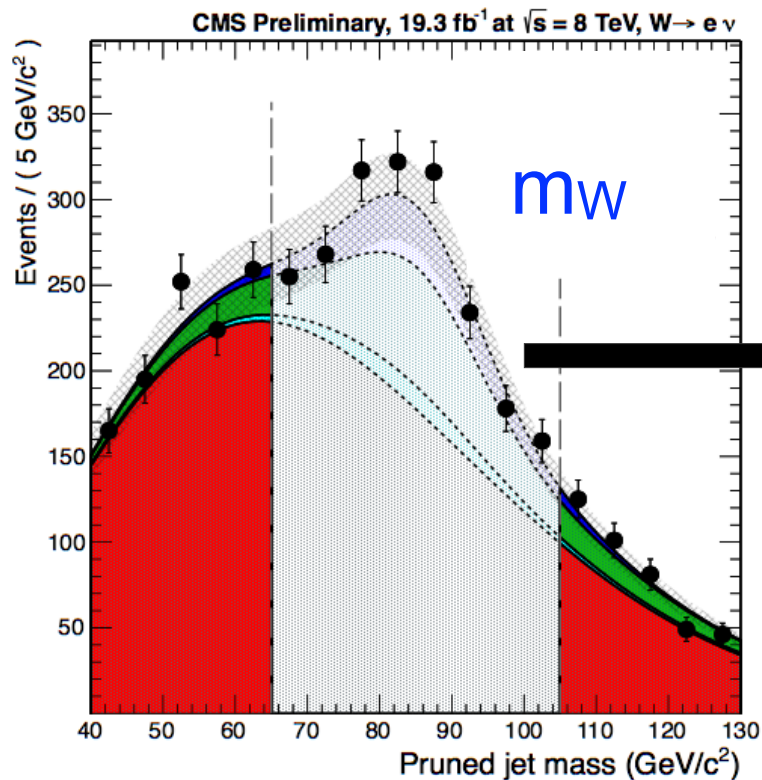

Optimize separately for each mass point ( $M_H$ : 170, 180, 190, 200, 250, ..., 600, 700, ..., 1000 GeV) and for the two lepton flavors (e,  $\mu$ ). Merged jet analysis for  $M_H > 600$  GeV.

# Constraints on higher mass Higgs states

No new states up to 600 GeV.

Eur. Phys. J. C 73, 2469 (2013)

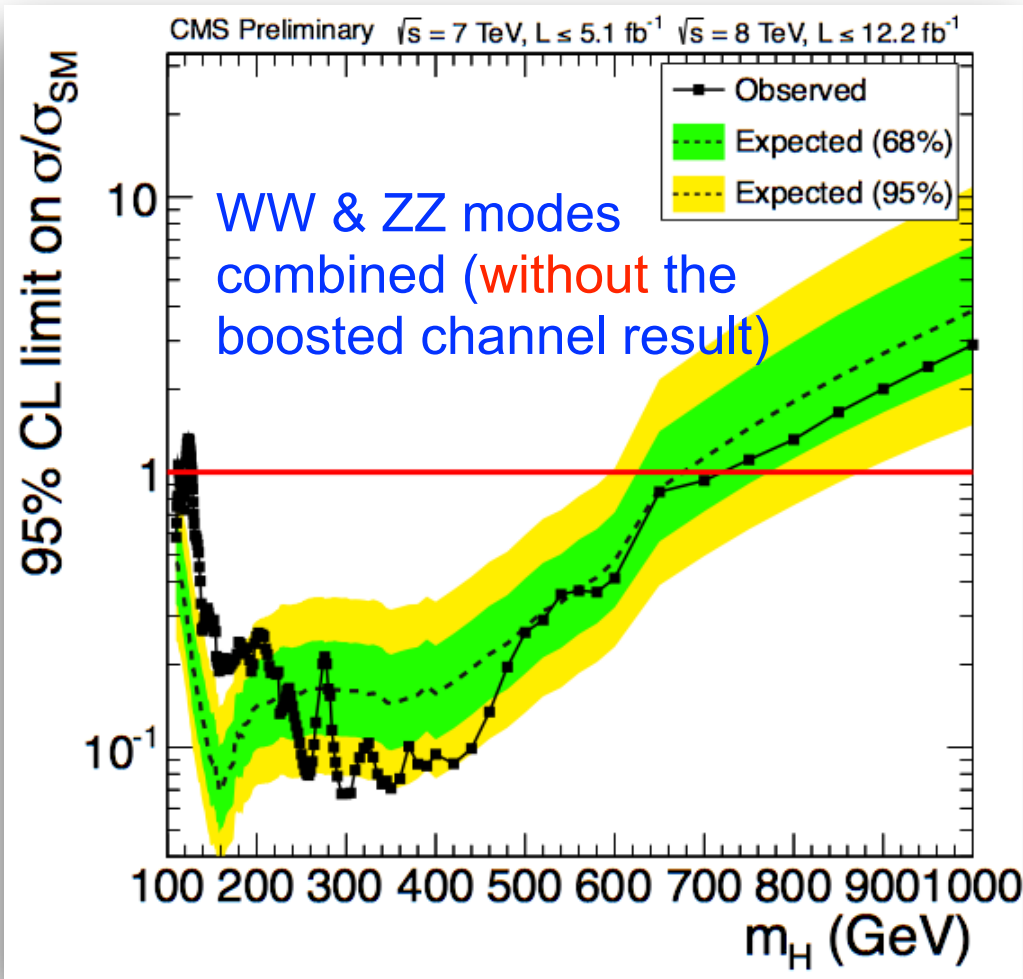

***But interesting territory > 600 GeV to probe at Run-2***

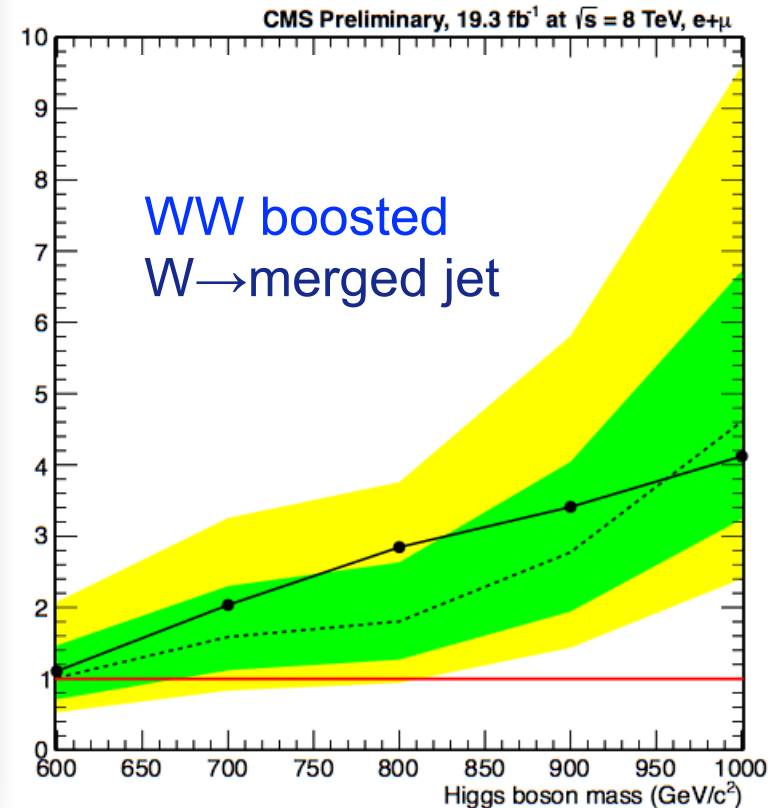

# Triggers

- ◆ All analyses shown here use single or di-lepton triggers
- ◆ Typical single lepton triggers require
  - one isolated lepton
  - threshold: 24 GeV for muon, 27 GeV for electron
  - MET > 20 GeV in case of electron
- ◆ Typical dilepton triggers require
  - two leptons, at least one isolated
  - each with threshold that varies between 5–20 GeV
- ◆ Offline analysis-level thresholds are higher than that in trigger. Simulation is corrected for trigger & selection efficiency.

# E.g., W charge & dipole moment in WZ events

CMS SMP-12-006

CMS Preliminary

$\sqrt{s} = 8 \text{ TeV}, L = 19.6 \text{ fb}^{-1}$

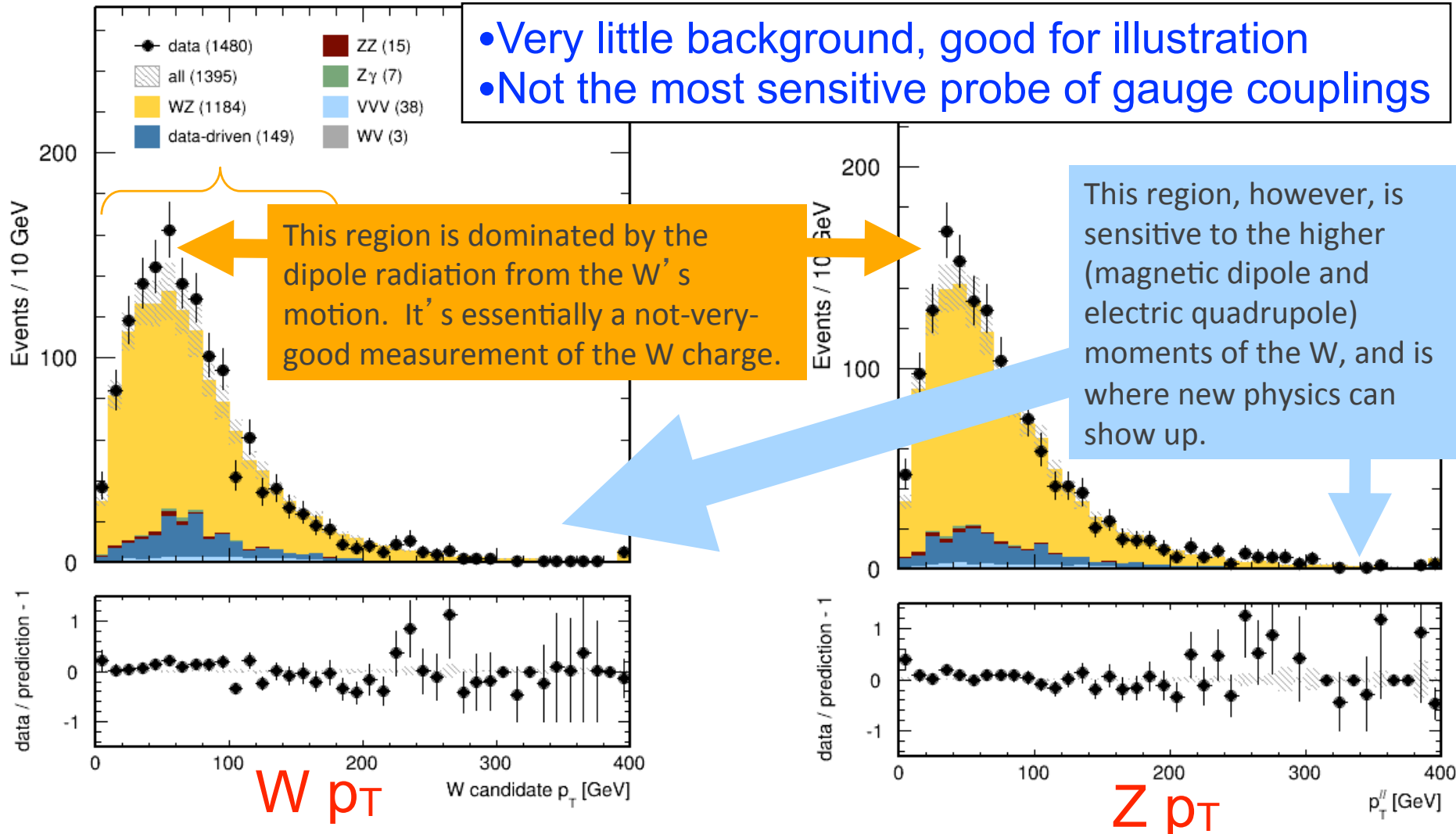

- Very little background, good for illustration
- Not the most sensitive probe of gauge couplings

This region is dominated by the dipole radiation from the W's motion. It's essentially a not-very-good measurement of the W charge.

This region, however, is sensitive to the higher (magnetic dipole and electric quadrupole) moments of the W, and is where new physics can show up.

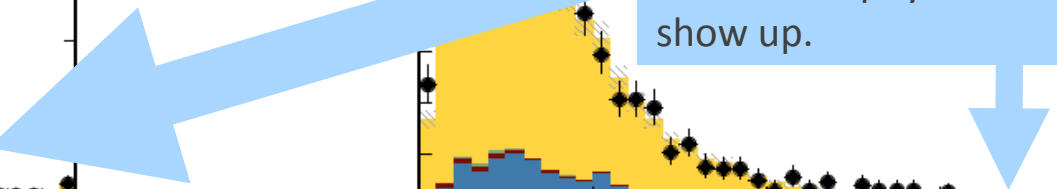

# A lesson from the past

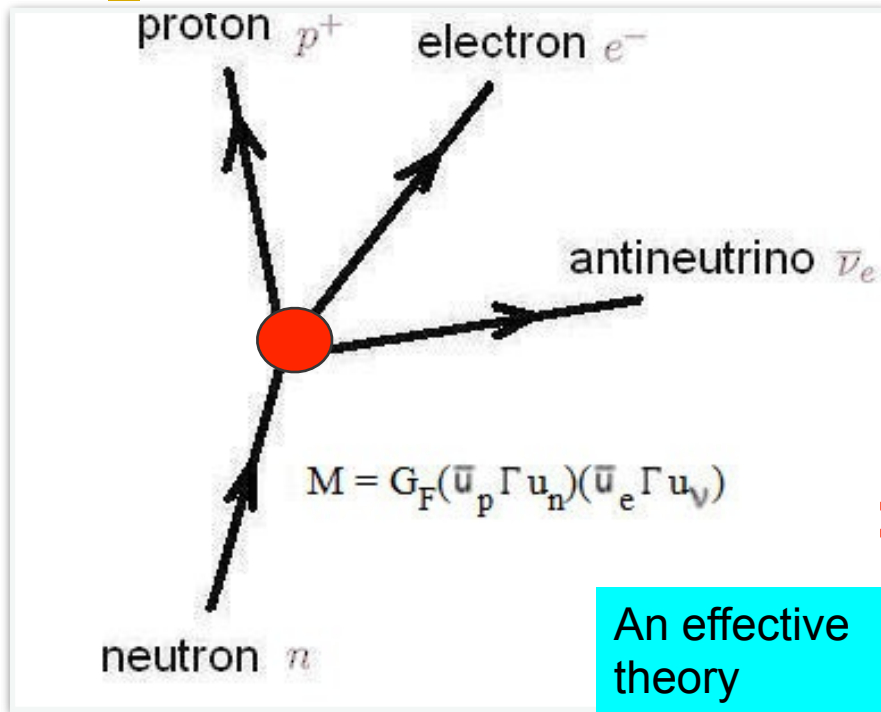

Fermi 4-point interaction, 1934

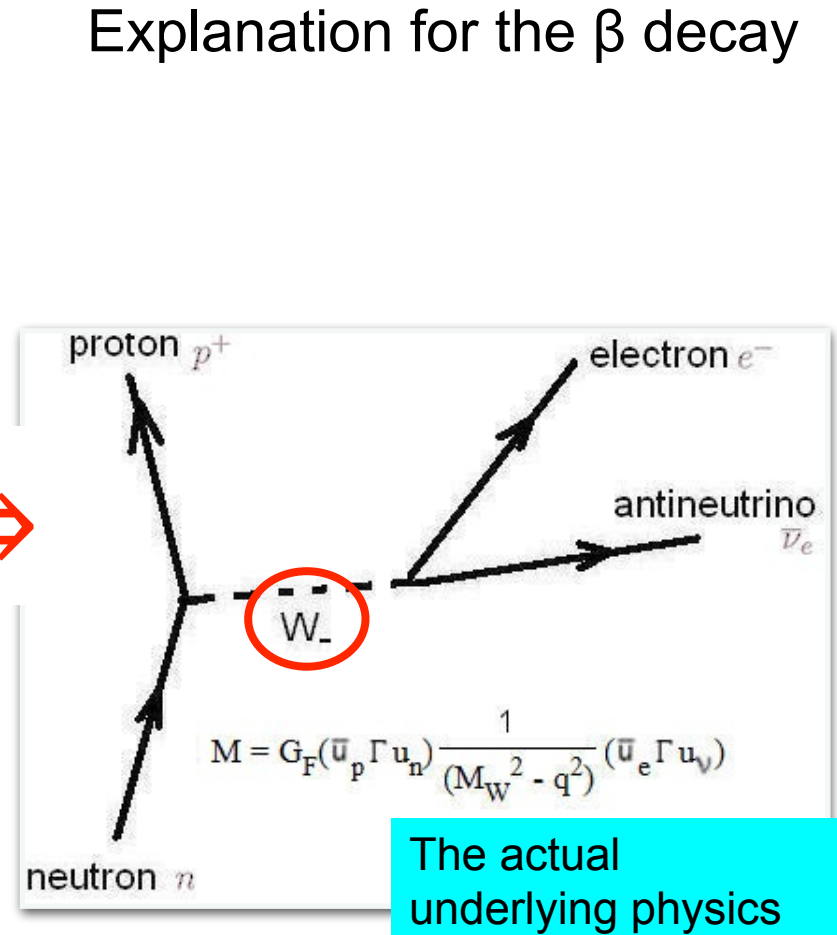

Weak interaction mediated by  $W$  boson, 1960's